

## CURRENT SENSOR

PRODUCT SERIES: STK-x.xP/Mx-X

PRODUCT PART NUMBER:

STK-0.3P/M1;STK-1.0P/M1;STK-1.0P/M1-1  
STK-0.3P/M1S;STK-1.0P/M1S;STK-1.0P/M1S-1  
STK-0.3P/M1A;STK-1.0P/M1A;STK-1.0P/M1A-1  
STK-0.3P/M1T;STK-1.0P/M1T;STK-1.0P/M1T-1  
STK-0.3P/M1F;STK-1.0P/M1F;STK-1.0P/M1F-1  
STK-0.3P/MN;STK-1.0P/MN;STK-1.0P/MN-1

REVISION: Ver 1.6



Sinomags Technology Co., Ltd.

Website: [www.sinomags.com](http://www.sinomags.com)

## CONTENT

1.	Description.....	2
2.	Absolute parameter.....	3
3.	STK-0.3P/Mx Electrical data.....	4
4.	STK-1.0P/Mx Electrical data.....	5
5.	STK-1.0P/Mx-1 Electrical data.....	6
6.	Application information.....	7
7.	STK-x.xP/M1-x Dimensions (in mm).....	8
8.	STK-x.xP/M1S-x Dimensions (in mm).....	9
9.	STK-x.xP/M1A-x Dimensions (in mm).....	10
10.	STK-x.xP/M1T-x Dimensions (in mm).....	11
11.	STK-x.xP/M1F-x Dimensions (in mm).....	12
12.	STK-x.xP/MN-x Dimensions (in mm).....	13
13.	STK-x.xP/M1-x Assembly on PCB.....	14
14.	STK-x.xP/M1S-x Assembly on PCB.....	15
15.	STK-x.xP/M1A-x Assembly on PCB.....	16
16.	STK-x.xP/M1T-x Assembly on PCB.....	17
17.	STK-x.xP/M1F-x Assembly on PCB.....	18
18.	STK-x.xP/MN-x Assembly on PCB.....	19

## 1. Description

### Features

- Open loop current transducer
- Voltage output
- Insulation voltage for 5kV/AC
- Single supply voltage
- PCB mounting
- Cobalt base magnetic ring.

### Applications

- Residual current measurement
- Leakage current measurement in transformerless PV inverters
- First human contact protection of PV arrays
- Failure detection in power sources
- Leakage current detection in stacked DC sources
- Communication power

### Advantages

- High accuracy
- High overload capability
- High insulation capability
- High separation ability
- Low temperature drift
- Degauss and test functions.

### Standards

- EN 50178
- IEC 61326-1: 2012

### Application Domain

- Industry.

## 2. Absolute parameter

### Absolute maximum ratings

Parameter	Symbol	Unit	Value
Supply voltage	V <sub>c</sub>	V	5.5
Primary conductor temperature	T <sub>B max</sub>	°C	110
Overload capability (100 μs, 500 A/μs)	I <sub>P max</sub>	A	3300
Maximum Primary current @ T <sub>Amax</sub> =105°C	I <sub>M</sub>	A/wire	STK-x.xP/M1-x: 60 STK-x.xP/M1S-x: 20 STK-x.xP/M1A-x: 32 STK-x.xP/M1T-x: 32 STK-x.xP/M1F-x: 32
Primary carrier resistance per wire @ T <sub>A</sub> =25°C	R <sub>p</sub>	mΩ	STK-x.xP/M1-x: 0.2 STK-x.xP/M1S-x: 0.36 STK-x.xP/M1A-x: 0.3 STK-x.xP/M1T-x: 0.3 STK-x.xP/M1F-x: 0.3

Stresses above these ratings may cause permanent damage. Exposure to absolute maximum ratings for extended periods may degrade reliability.

### Isolation parameters

Parameter	Symbol	Unit	Value
RMS voltage for AC test 50Hz/1min	V <sub>d</sub>	kV	5
Impulse withstand voltage 1.2/50μs	V <sub>w</sub>	kV	10.1
Comparative tracking index	CTI	V	600
Case material			V0 according to UL 94

### Environmental and mechanical characteristics

Parameter	Symbol	Unit	Min	Typ	Max
Ambient operating temperature	T <sub>A</sub>	°C	-40		105
Ambient storage temperature	T <sub>S</sub>	°C	-45		125
Mass	m	g		STK-x.xP/M1-x: 35 STK-x.xP/M1S-x: 18 STK-x.xP/M1A-x: 30 STK-x.xP/M1T-x: 33 STK-x.xP/M1F-x: 36 STK-x.xP/MN-x: 15	
standard	EN 50178, IEC 61010-1, UL 508				

### 3. STK-0.3P/Mx Electrical data

 STK-0.3P/Mx at  $T_A = 25^\circ\text{C}$ ,  $V_C = 5\text{ V}$ .

Parameters	Symbol	Unit	Min	Typ	Max	Remark
Primary nominal residual rms current	$I_{pn}$	A		0.3		
Primary residual current, measuring range	$I_{pm}$	A	-0.5		0.5	
Supply voltage	$V_C$	V	4.9	5	5.1	
Current consumption	$I_C$	mA		18		$I_P(\text{mA}) / N_a$ $N_a = 40$ turns -40°C ... 105°C
Reference voltage @ $I_P = 0$	$V_{ref}$	V	2.475	2.5	2.525	Internal reference
Temperature coefficient of $V_{ref}$ @ $I_P = 0$	$TCV_{ref}$	ppm/K		$\pm 100$	$\pm 250$	ppm/K of 2.5 V -40 ... 105 °C
Electrical offset voltage	$V_{oe}$	mV	-25		25	$(V_{out} - V_{ref})$ @ 0 A
Temperature coefficient of $V_{OE}$ @ $I_P = 0$	$TCV_{oe}$	ppm/K		$\pm 100$	$\pm 300$	ppm/K of 2.5 V -40 ... 105 °C
Theoretical sensitivity	$G_{th}$	V/A		4		
Temperature coefficient of $G_{th}$	$TCG$	ppm/K		$\pm 300$	$\pm 400$	-40°C ... 105°C
Sensitivity error	$\epsilon_G$	%	-2	1	2	
Linearity error	$\epsilon_L$	%		0.5	1	
Check current	$I_{ck}$	mA		50		Sum of 20turns
Output voltage(Checkfunction)	$V_{CK}$	V	0.194	$V_{oe} + 0.2$	0.206	
Check enable voltage	$V_{CE}$	V	3.3		$V_C$	
Check disabled voltage	$V_{CD}$	V		< 0.2		
Frequency bandwidth (-3dB)	BW	Hz		700		
Noise(1 Hz ~ 10 kHz)	$V_{no}$	mV rms		10		
Reaction time @ 10 % of $I_{PN}$	$t_{ra}$	$\mu\text{s}$		100		$R_L > 500\text{ k}\Omega$ , $di/dt > 5\text{ A}/\mu\text{s}$
Step response time to 90 % of $I_{PN}$	$t_r$	$\mu\text{s}$		700		$R_L > 500\text{ k}\Omega$ , $di/dt > 5\text{ A}/\mu\text{s}$
Accuracy@ $I_{PN}$ @ $T_A = 25^\circ\text{C}$	$X_{25^\circ\text{C}}$	% of $I_{PN}$		$\pm 2$		
Accuracy@ $I_{PN}$ @ $T_A = 105^\circ\text{C}$	$X_{105^\circ\text{C}}$	% of $I_{PN}$		$\pm 4$		
Output internal resistance	$R_{out}$	$\Omega$		49.9		
$V_{ref}$ internal resistance	$R_{ref}$	$\Omega$		49.9		

#### 4. STK-1.0P/Mx Electrical data

 STK-1.0P/Mx at  $T_A = 25^\circ\text{C}$ ,  $V_C = 5\text{ V}$ .

Parameters	Symbol	Unit	Min	Typ	Max	Remark
Primary nominal residual rms current	$I_{pn}$	A		1.02		
Primary residual current, measuring range	$I_{pm}$	A	-1.7		1.7	
Supply voltage	$V_C$	V	4.9	5	5.1	
Current consumption	$I_C$	mA		18		$I_P(\text{mA}) / N_a$ $N_a = 40$ turns -40°C ... 105°C
Reference voltage @ $I_P = 0$	$V_{ref}$	V	2.475	2.5	2.525	Internal reference
Temperature coefficient of $V_{ref}$ @ $I_P = 0$	$TCV_{ref}$	ppm/K		$\pm 100$	$\pm 250$	ppm/K of 2.5 V -40 ... 105 °C
Electrical offset voltage	$V_{oe}$	mV	-25		25	$(V_{out} - V_{ref})$ @ 0 A
Temperature coefficient of $V_{OE}$ @ $I_P = 0$	$TCV_{oe}$	ppm/K		$\pm 100$	$\pm 300$	ppm/K of 2.5 V -40 ... 105 °C
Theoretical sensitivity	$G_{th}$	V/A		1.17		
Temperature coefficient of $G_{th}$	$TCG$	ppm/K		$\pm 300$	$\pm 400$	-40°C ... 105°C
Sensitivity error	$\epsilon_G$	%	-2	1	2	
Linearity error	$\epsilon_L$	%		0.5	1	
Check current	$I_{ck}$	mA		170		
Output voltage(Checkfunction)	$V_{CK}$	V	0.194	$V_{oe} + 0.2$	0.206	Sum of 20turns
Check enable voltage	$V_{CE}$	V	3.3		$V_C$	
Check disabled voltage	$V_{CD}$	V		< 0.2		
Frequency bandwidth (-3dB)	BW	Hz		700		
Noise(1 Hz ~ 10 kHz)	$V_{no}$	mV rms		10		
Reaction time @ 10 % of $I_{PN}$	$t_{ra}$	$\mu\text{s}$		100		$R_L > 500\text{ k}\Omega$ , $di/dt > 5\text{ A}/\mu\text{s}$
Step response time to 90 % of $I_{PN}$	$t_r$	$\mu\text{s}$		700		$R_L > 500\text{ k}\Omega$ , $di/dt > 5\text{ A}/\mu\text{s}$
Accuracy@ $I_{PN}$ @ $T_A = 25^\circ\text{C}$	$X_{25^\circ\text{C}}$	% of $I_{PN}$		$\pm 2$		
Accuracy@ $I_{PN}$ @ $T_A = 105^\circ\text{C}$	$X_{105^\circ\text{C}}$	% of $I_{PN}$		$\pm 4$		
Output internal resistance	$R_{out}$	$\Omega$		499		
$V_{ref}$ internal resistance	$R_{ref}$	$\Omega$		499		

## 5. STK-1.0P/Mx-1 Electrical data

 STK-1.0P/Mx-1 at  $T_A = 25^\circ\text{C}$ ,  $V_C = 5\text{ V}$ .

Parameters	Symbol	Unit	Min	Typ	Max	Remark
Primary nominal residual rms current	$I_{pn}$	A		1		
Primary residual current, measuring range	$I_{pm}$	A	-1.7		1.7	
Supply voltage	$V_C$	V	4.9	5	5.1	
Current consumption	$I_C$	mA		18		$I_P(\text{mA}) / N_a$ $N_a = 40$ turns -40°C ... 105°C
Reference voltage @ $I_P = 0$	$V_{ref}$	V	2.475	2.5	2.525	Internal reference
Temperature coefficient of $V_{ref}$ @ $I_P = 0$	$TCV_{ref}$	ppm/K		$\pm 100$	$\pm 250$	ppm/K of 2.5 V -40 ... 105 °C
Electrical offset voltage	$V_{oe}$	mV	-25		25	$(V_{out} - V_{ref})$ @ 0 A
Temperature coefficient of $V_{OE}$ @ $I_P = 0$	$TCV_{oe}$	ppm/K		$\pm 100$	$\pm 300$	ppm/K of 2.5 V -40 ... 105 °C
Theoretical sensitivity	$G_{th}$	V/A		1.2		
Temperature coefficient of $G_{th}$	$TCG$	ppm/K		$\pm 300$	$\pm 400$	-40°C ... 105°C
Sensitivity error	$\epsilon_G$	%	-2	1	2	
Linearity error	$\epsilon_L$	%		0.5	1	
Check current	$I_{ck}$	mA		166		Sum of 20turns
Output voltage(Checkfunction)	$V_{CK}$	V	0.194	$V_{oe} + 0.2$	0.206	
Check enable voltage	$V_{CE}$	V	3.3		$V_C$	
Check disabled voltage	$V_{CD}$	V		< 0.2		
Frequency bandwidth (-3dB)	$BW$	Hz		700		
Noise(1 Hz ~ 10 kHz)	$V_{no}$	mV rms		10		
Reaction time @ 10 % of $I_{PN}$	$t_{ra}$	$\mu\text{s}$		100		$R_L > 500\text{ k}\Omega$ , $di/dt > 5\text{ A}/\mu\text{s}$
Step response time to 90 % of $I_{PN}$	$t_r$	$\mu\text{s}$		700		$R_L > 500\text{ k}\Omega$ , $di/dt > 5\text{ A}/\mu\text{s}$
Accuracy@ $I_{PN}$ @ $T_A = 25^\circ\text{C}$	$X_{25^\circ\text{C}}$	% of $I_{PN}$		$\pm 2$		
Accuracy@ $I_{PN}$ @ $T_A = 105^\circ\text{C}$	$X_{105^\circ\text{C}}$	% of $I_{PN}$		$\pm 4$		
Output internal resistance	$R_{out}$	$\Omega$		49.9		
$V_{ref}$ internal resistance	$R_{ref}$	$\Omega$		49.9		

## 6. Application information

### Application circuit

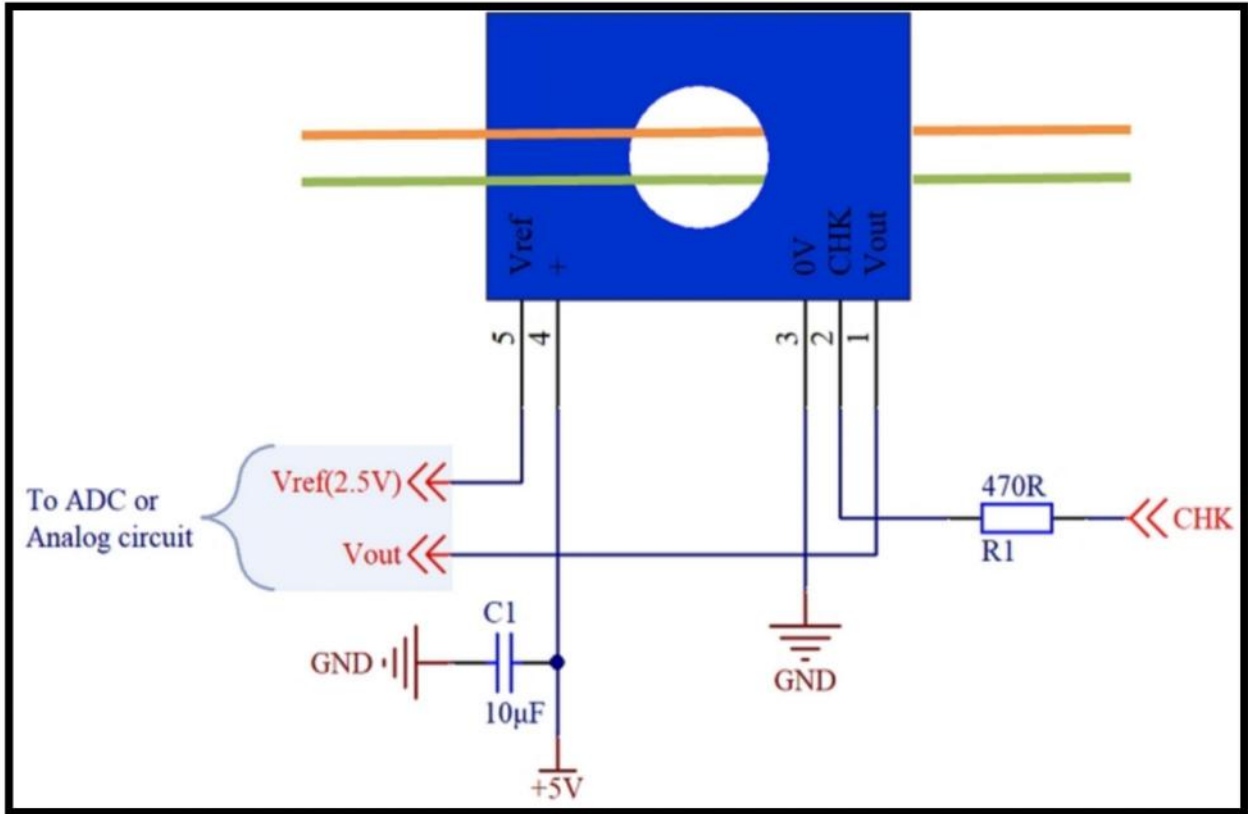

### Self-check Function

Set the CHK pin to high status. STK-x.xP/Mx-x will run in self-test mode, check the out pin, equivalent to the status  $I_p$  is  $I_{ck}$ , at this time the output has equal voltage, the detector is OK. Then sets CHK to low voltage  $V_{CD} < 0.2V$ , the sensor starts to run in the residual current.



## 7. STK-x.xP/M1-x Dimensions (in mm)

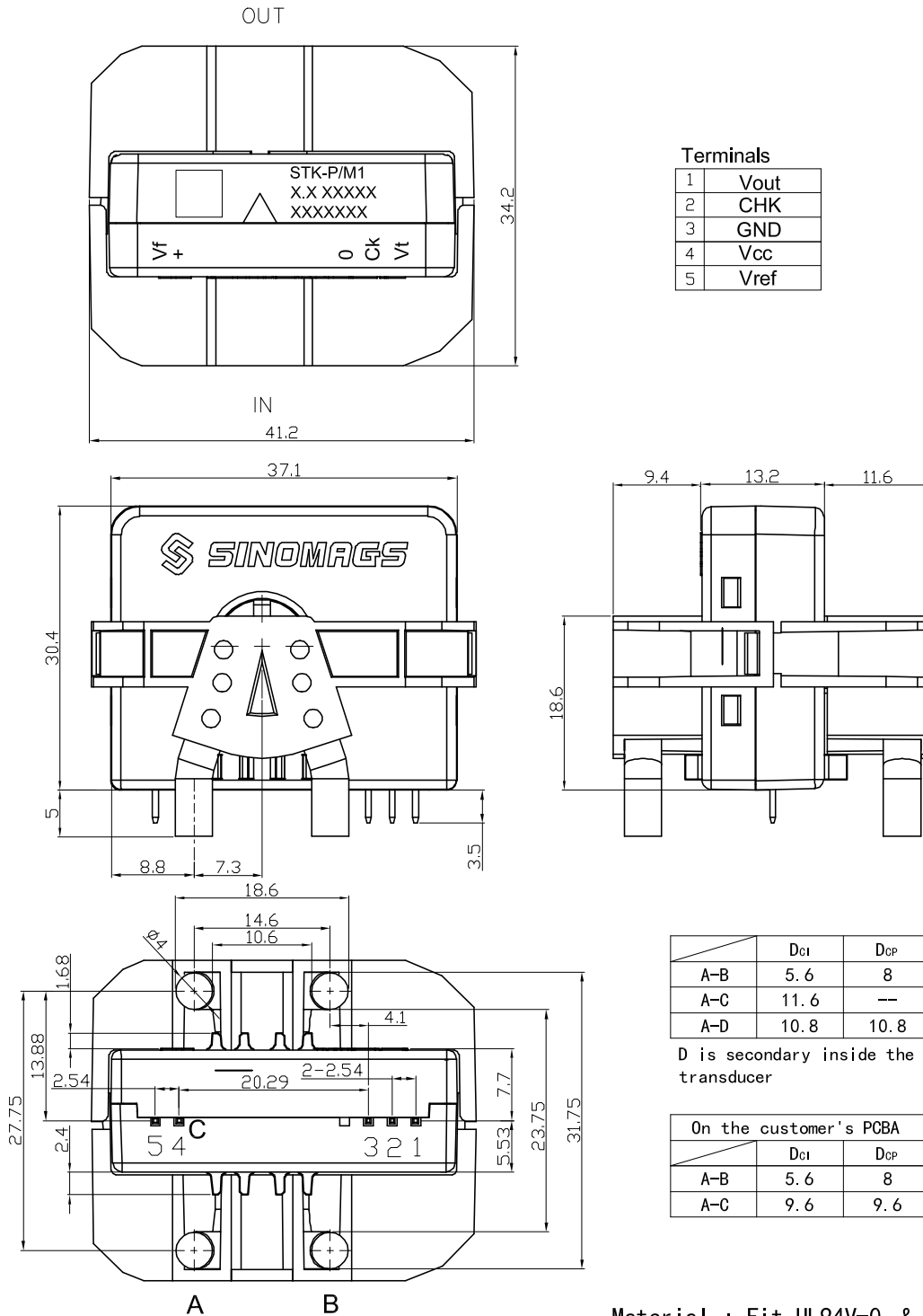

Material : Fit UL94V-0 & RoHS requirements ;  
 General tolerance :  $\pm 0.5$   
 Unit : mm

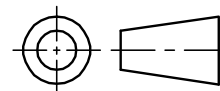

### 8. STK-x.xP/M1S-x Dimensions (in mm)

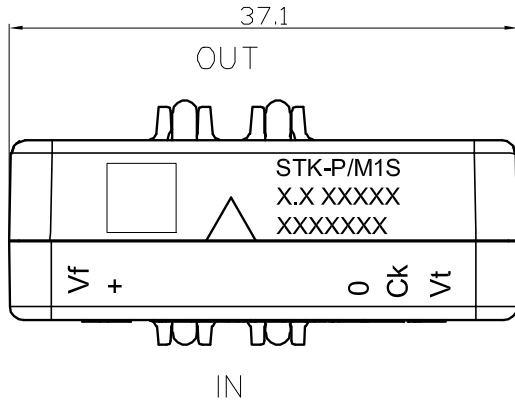

Terminals

1	Vout
2	CHK
3	GND
4	Vcc
5	Vref

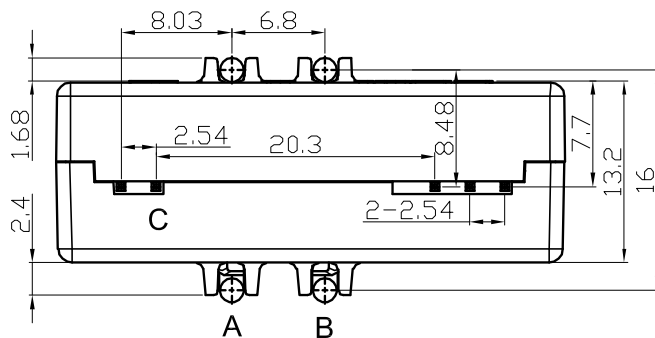
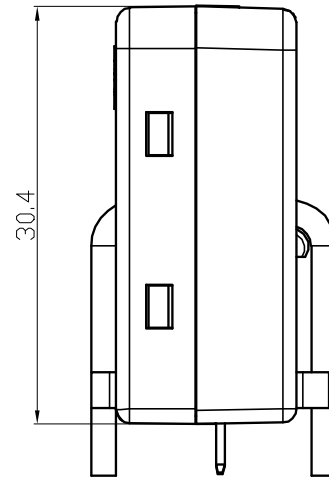
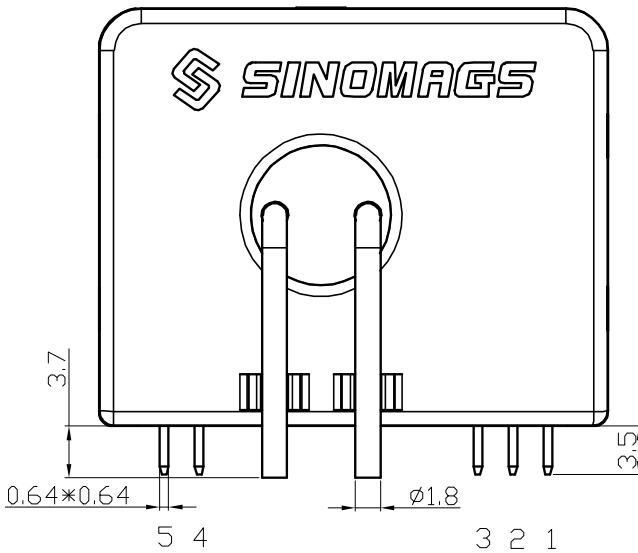

	D <sub>CI</sub>	D <sub>CP</sub>
A-B	5	5.5
A-C	8	--
A-D	--	9

D is secondary inside the transducer

On the customer's PCBA		
	D <sub>CI</sub>	D <sub>CP</sub>
A-B	2.3	2.3
A-C	6	6

Material : Fit UL94V-0 & RoHS requirements ;

General tolerance :  $\pm 0.5$

Unit :mm

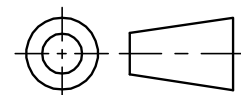

## 9. STK-x.xP/M1A-x Dimensions (in mm)

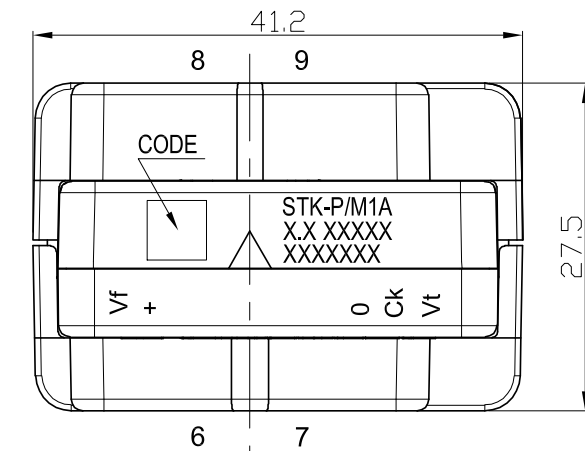

	$d_{CI}$	$d_{CP}$
C-B	10.7mm	---
A-C	5.2mm	6mm
C-D	12mm	16.0mm

D is secondary inside the transducer

On the customer's PCBA		
	$d_{CI}$	$d_{CP}$
C-B	9.1mm	9.1mm
A-C	4.4mm	4.4mm

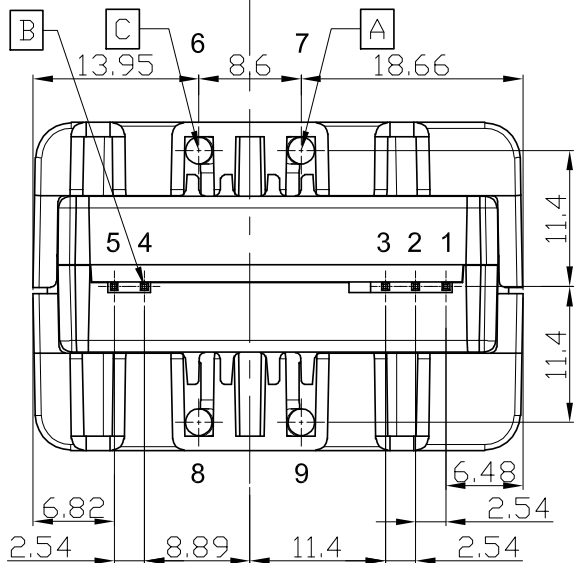
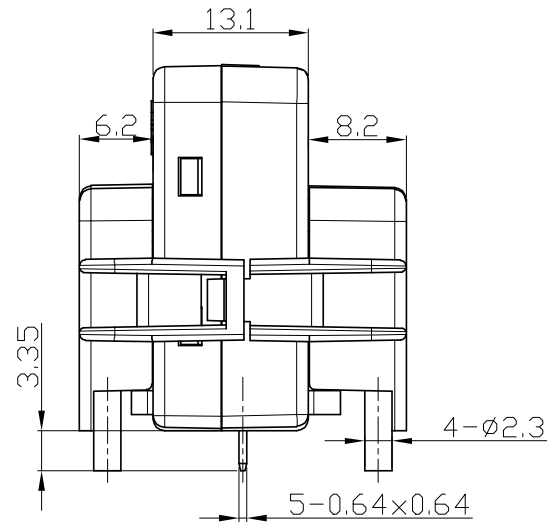
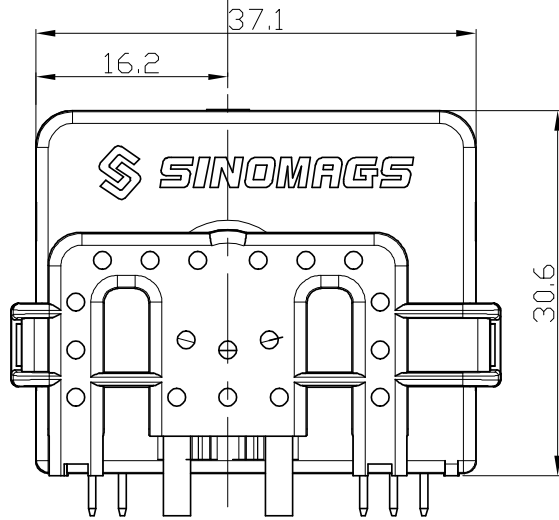

### Terminals

1	Vout	6	Ip+
2	CHK	7	Ip+
3	GND	8	Ip-
4	Vcc	9	Ip-
5	Vref		

Material : Fit UL94V-0 & RoHS requirements ;  
 General tolerance :  $\pm 0.5$   
 Unit : mm

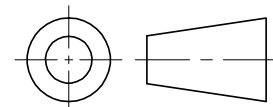

### 10. STK-x.xP/M1T-x Dimensions (in mm)

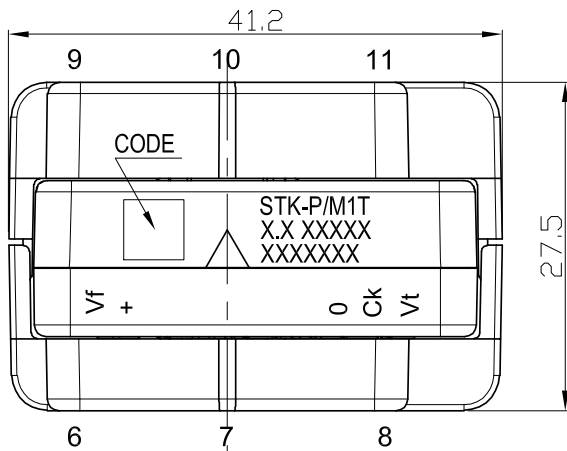

	$d_{CI}$	$d_{CP}$
C-B	9.9mm	---
A-C	3.7mm	8.5mm
C-D	11.6mm	15.7mm

D is secondary inside the transducer

On the customer's PCBA		
	$d_{CI}$	$d_{CP}$
C-B	8.3mm	8.3mm
A-C	3.7mm	8.5mm

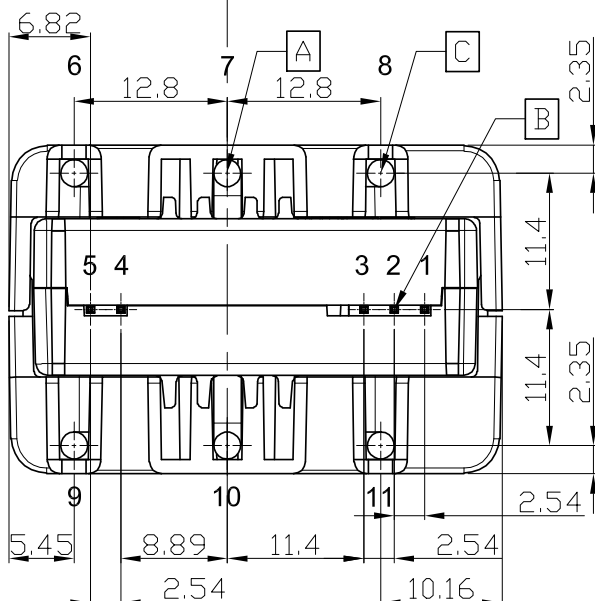
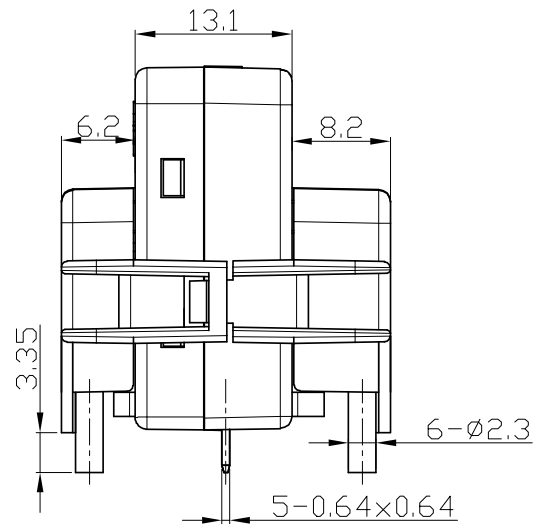
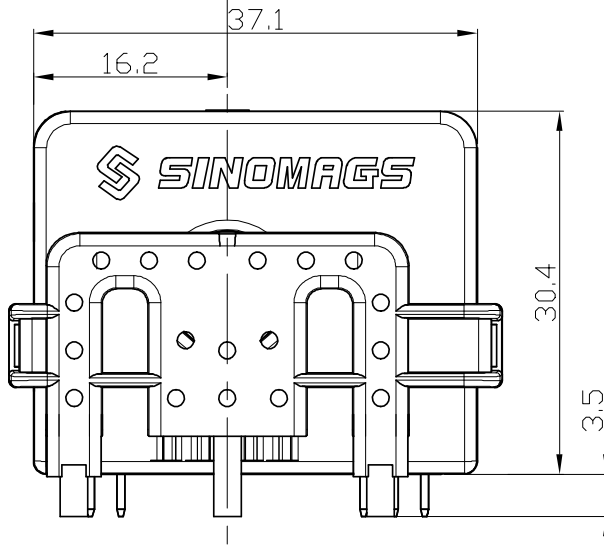

#### Terminals

1	Vout	6	Ip+	9	Ip-
2	CHK	7	Ip+	10	Ip-
3	GND	8	Ip+	11	Ip-
4	Vcc				
5	Vref				

Material : Fit UL94V-0 & RoHS requirements ;

General tolerance :  $\pm 0.5$

Unit :mm

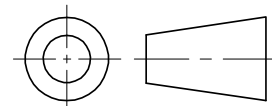

### 11. STK-x.xP/M1F-x Dimensions (in mm)

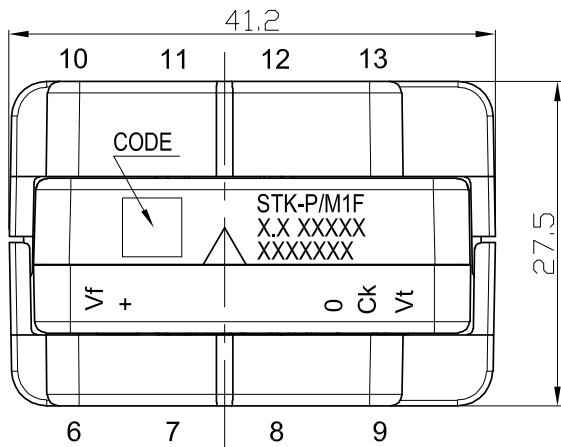

	d <sub>CI</sub>	d <sub>CP</sub>
C-B	9.9mm	---
A-C	4.5mm	6mm
C-D	11.6mm	16.0mm

D is secondary inside the transducer

On the customer's PCBA		
	d <sub>CI</sub>	d <sub>CP</sub>
C-B	8.3mm	8.3mm
A-C	4.3mm	4.3mm

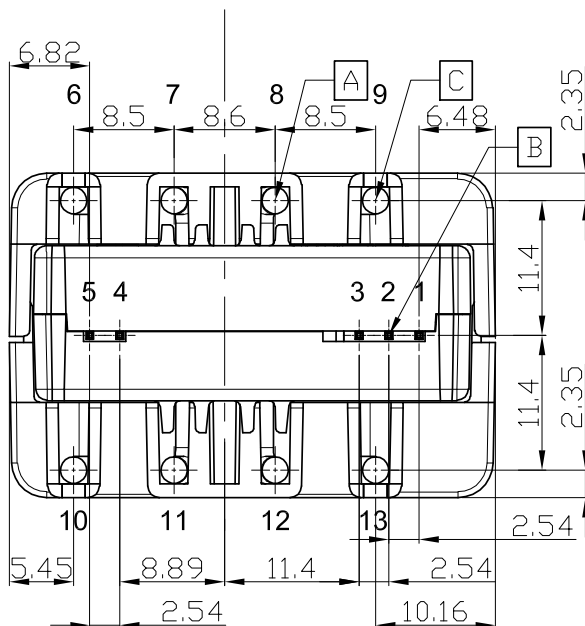
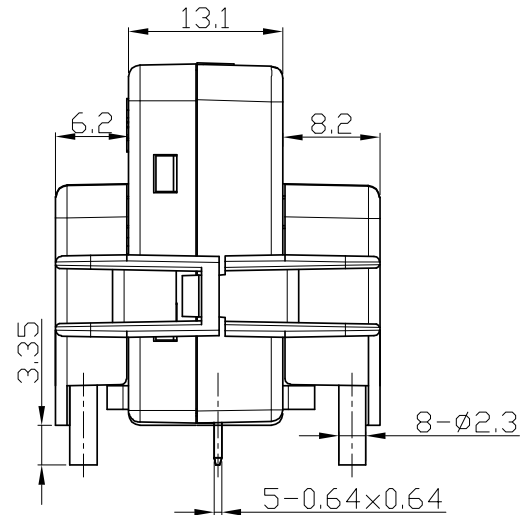
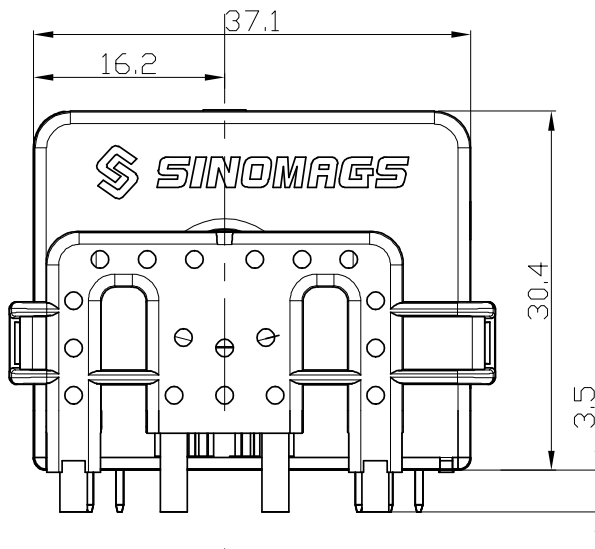

#### Terminals

1	Vout	6	Ip+	10	Ip-
2	CHK	7	Ip+	11	Ip-
3	GND	8	Ip+	12	Ip-
4	Vcc	9	Ip+	13	Ip-
5	Vref				

Material : Fit UL94V-0 & RoHS requirements ;

General tolerance : ±0.5

Unit :mm

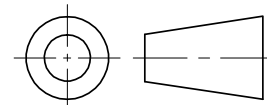

## 12. STK-x.xP/MN-x Dimensions (in mm)

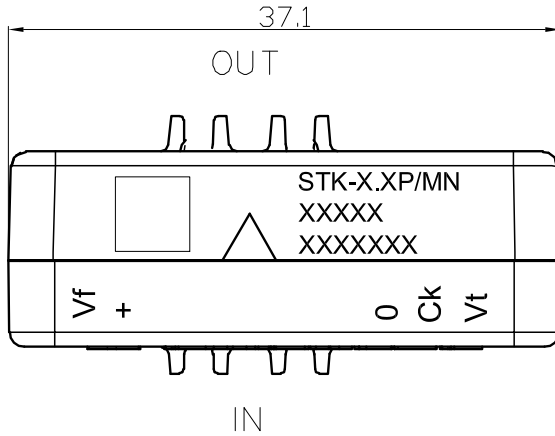

Terminals

1	Vout
2	CHK
3	GND
4	Vcc
5	Vref

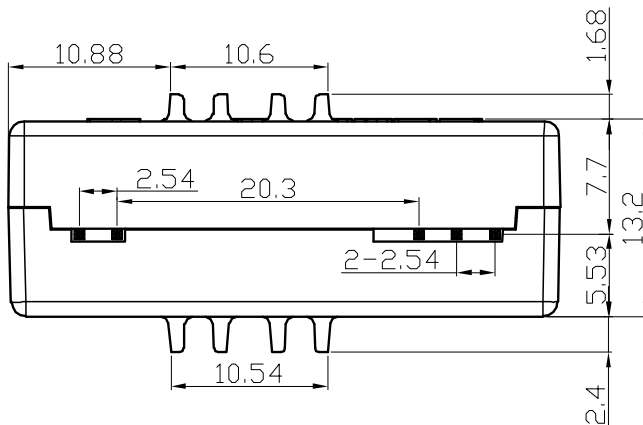
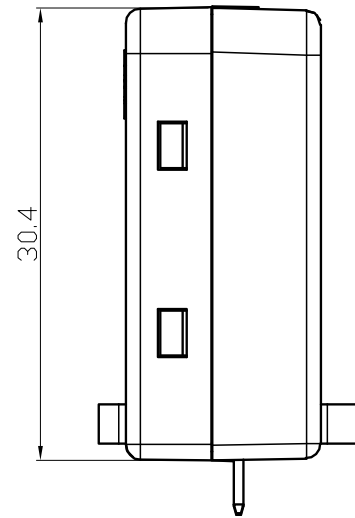
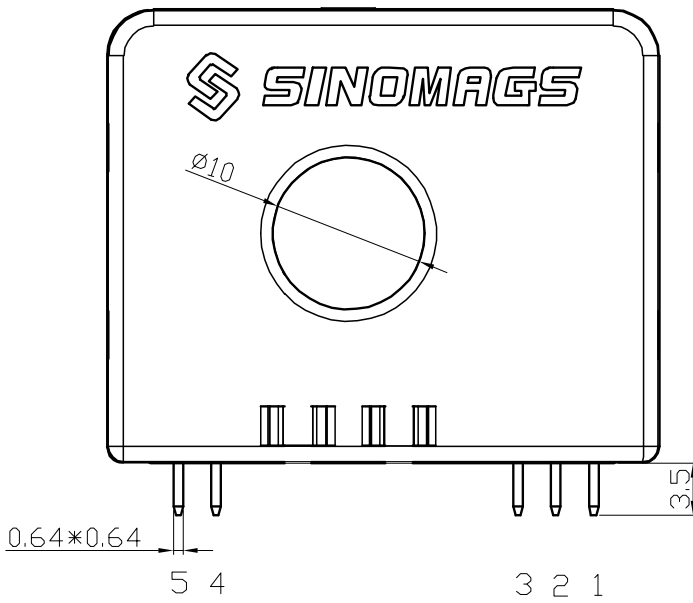

Material : Fit UL94V-0 & RoHS requirements ;  
General tolerance :  $\pm 0.5$   
Unit :mm

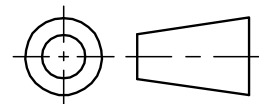

### 13. STK-x.xP/M1-x Assembly on PCB

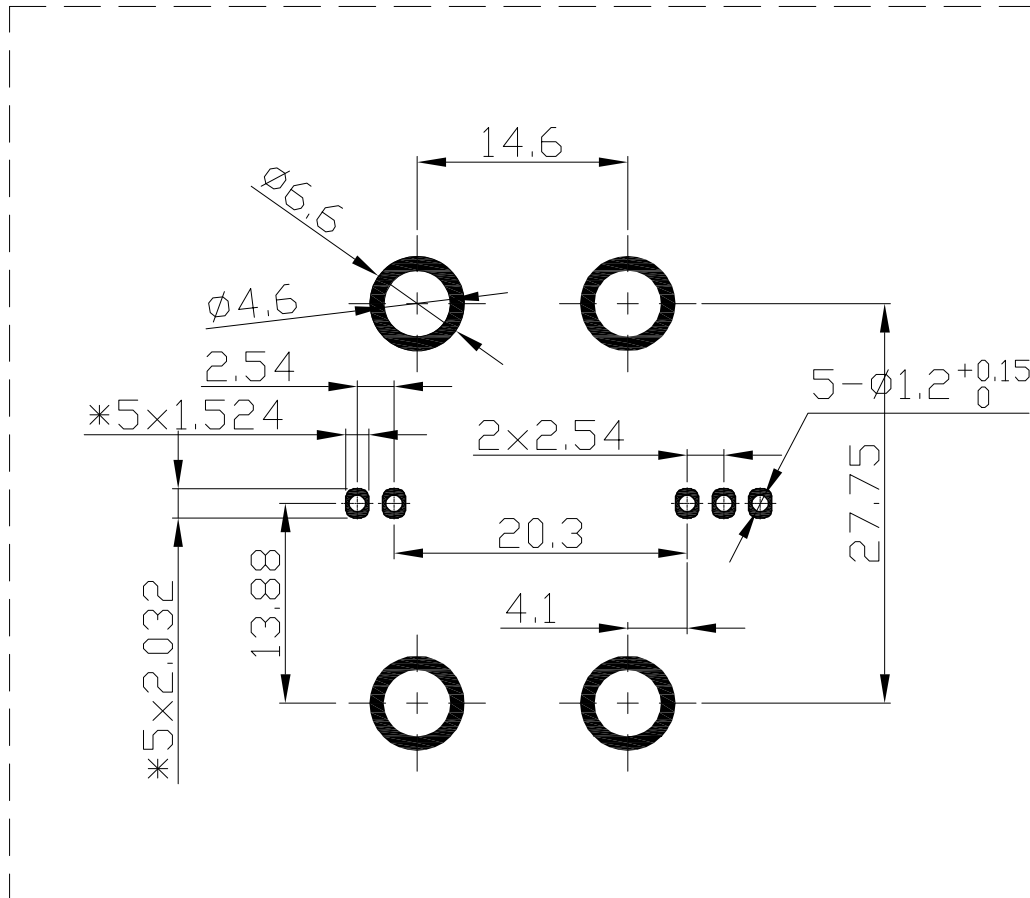

- Maximum PCB thickness 2.4 mm
- Wave-soldering: 260°C @ 10 s
- Recommended PCB hole diameter 1.2 mm for secondary pin.

## 14. STK-x.xP/M1S-x Assembly on PCB

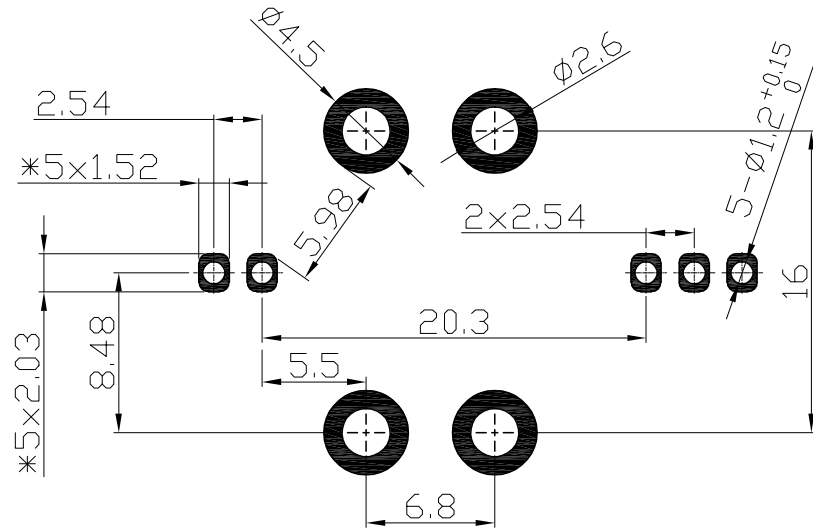

Top side view

- Maximum PCB thickness 2.4 mm
- Wave-soldering: 260°C @ 10 s
- Recommended PCB hole diameter 1.2 mm for secondary pin.



### 15. STK-x.xP/M1A-x Assembly on PCB

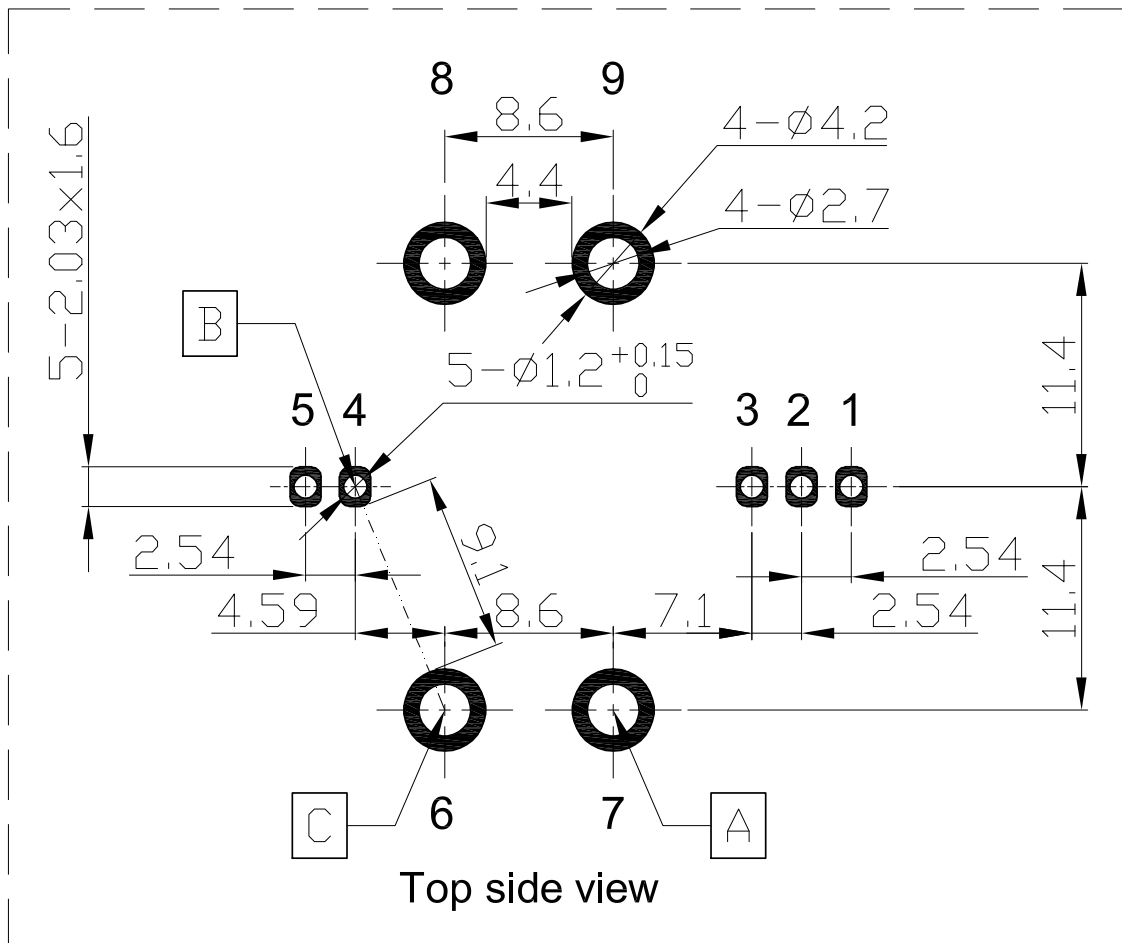

- Maximum PCB thickness 2.4 mm
- Wave-soldering: 260°C @ 10 s
- Recommended PCB hole diameter 1.2 mm for secondary pin.

## 16. STK-x.xP/M1T-x Assembly on PCB

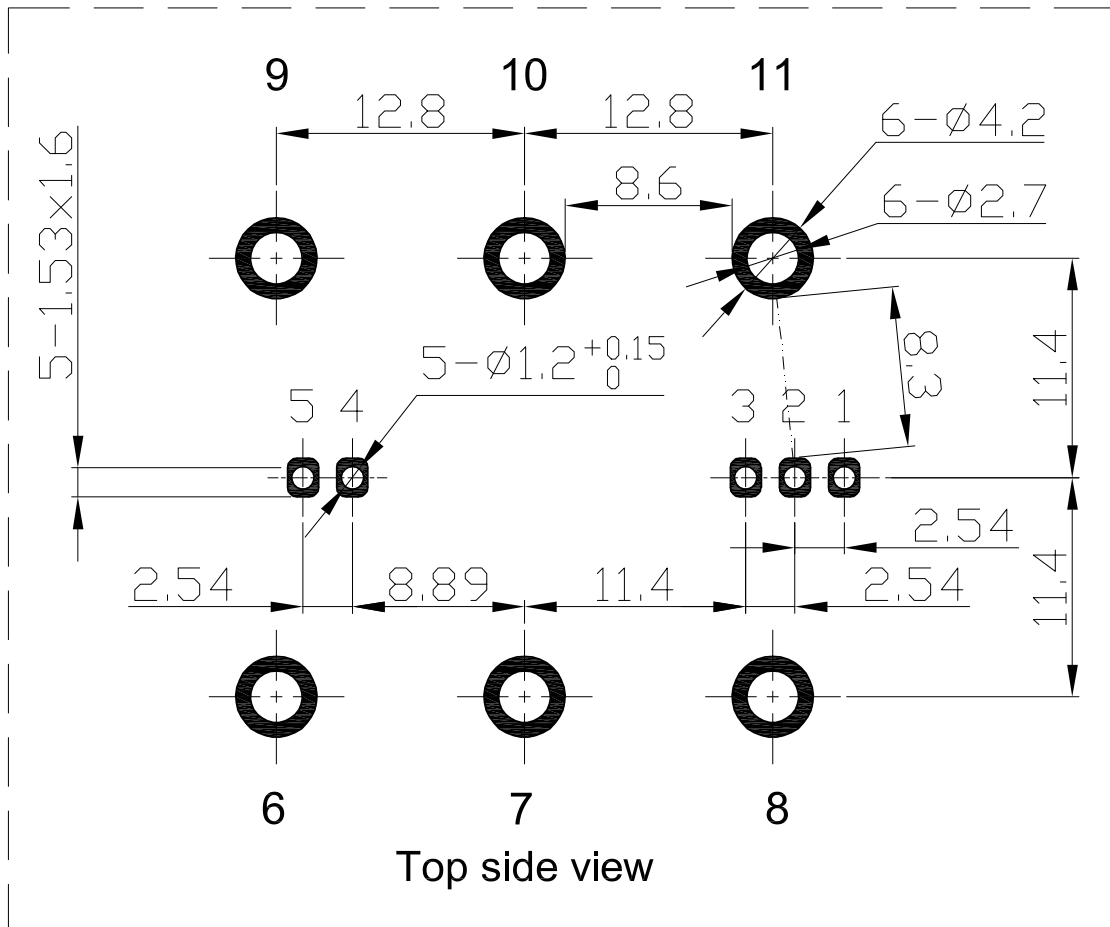

- Maximum PCB thickness 2.4 mm
- Wave-soldering: 260°C @ 10 s
- Recommended PCB hole diameter 1.2 mm for secondary pin.

### 17. STK-x.xP/M1F-x Assembly on PCB

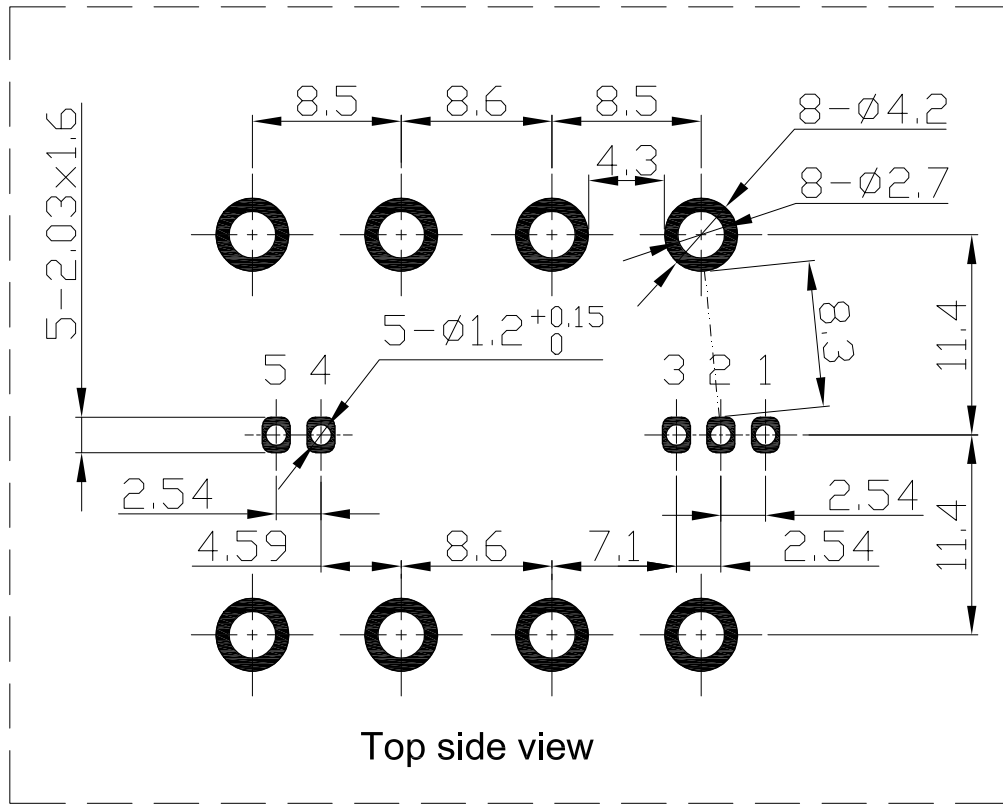

- Maximum PCB thickness 2.4 mm
- Wave-soldering: 260°C @ 10 s
- Recommended PCB hole diameter 1.2 mm for secondary pin.

## 18. STK-x.xP/MN-x Assembly on PCB

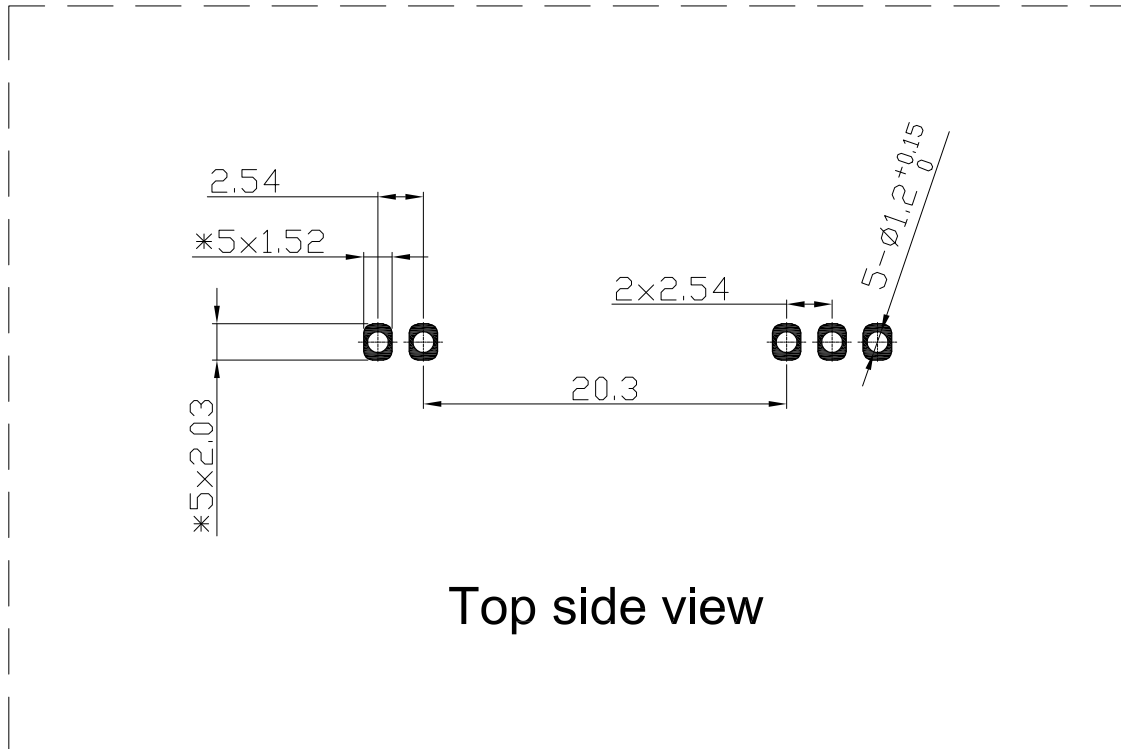

- Maximum PCB thickness 2.4 mm
- Wave-soldering: 260°C @ 10 s
- Recommended PCB hole diameter 1.2 mm for secondary pin.