

Current Sensor

Product Series: STK-616A

Part number: STK-616A-6AB
STK-616A-12AB
STK-616A-25AB
STK-616A-50AB
STK-616A-60AC
STK-616A-80AB

Version: Ver 1.6

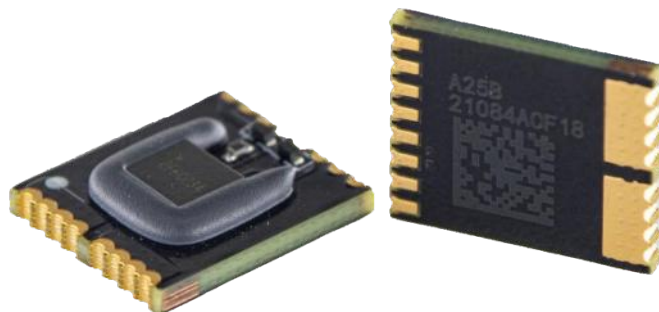

CONTENT

1.	Description	2
2.	Part number definition	4
3.	Temperature vs Current	4
4.	Electrical data	5
5.	Dimensions	7
6.	Pin definitions	8
7.	PCB layout recommendation	8
8.	Frequency band width	9
9.	Step response time	9
10.	Block diagram	10
11.	Typical application circuit	10
12.	OCD voltage	11
13.	OCD function for STK-616A-25A	12
14.	OCD function for STK-616A-50A	13
15.	OCD function for STK-616A-80A	14
16.	General information on OCD	15

1. Description

The STK-616A series current sensor is based on TMR (tunnel magnetoresistance) technology and open-loop design. It is suitable for DC, AC pulsed and any kind of irregular current measurement under the isolated conditions.

The STK-616A series current sensor has build-in OCD (Over Current Detection) function.

Typical applications

- AC Variable speed drives
- Inverter
- Power supply

General parameter

Parameter	Symbol	Unit	Value
Junction temperature	T_A	°C	-40 ~ 125
Storage temperature	T_stg	°C	-40 ~ 125
Mass	m	g	2

Absolute maximum rating

Parameter	Symbol	Unit	Value
Supply voltage	V _{cc}	V	5
ESD rating (HBM)	U_ESD	kV	4

Remark: the unrecoverable damage may occur when the product works on the conditions over the absolute maximum ratings. Long-time working on the absolute maximum ratings may cause the degradation on performance and reliability.

Isolation parameter

Parameter	Symbol	Unit	Value	Comment
RMS voltage for AC test 50 Hz, 1 min	U _d	kV	4	
Impulse withstand voltage 1.2/50μs	Ū _w	kV	8	
Clearance distance (pri. -sec)	d _{Cl}	mm	6	
Creepage distance (pri. -sec)	d _{Cp}	mm	6	

Measuring current table

Part number	Current Range	Sensitivity (mV/A)	T (°C)
STK-616A-25AB-1-1.65-E-2-C	±25 A	48	-40 ~ 105
STK-616A-50AB-1-1.65-E-2-C	±50 A	24	-40 ~ 105
STK-616A-60AB-1-1.65-E-3-C	±60 A	12	-40 ~ 105
STK-616A-80AB-1-1.65-E-3-C	±80 A	15	-40 ~ 105
STK-616A-25AB-1-1.65-E-1-C	±25 A	48	-40 ~ 105
STK-616A-25AB-1-1.65-E-3-C	±25 A	48	-40 ~ 105
STK-616A-12AB-1-1.65-E-1-C	±12 A	100	-40 ~ 105

STK-616A-12AB-1-1.65-E-2-C	± 12 A	100	-40 ~ 105
STK-616A-12AB-1-1.65-E-3-C	± 12 A	100	-40 ~ 105
STK-616A-6AB-1-1.65-E-1-C	± 6 A	200	-40 ~ 105
STK-616A-6AB-1-1.65-E-2-C	± 6 A	200	-40 ~ 105
STK-616A-6AB-1-1.65-E-3-C	± 6 A	200	-40 ~ 105

2. Part number definition

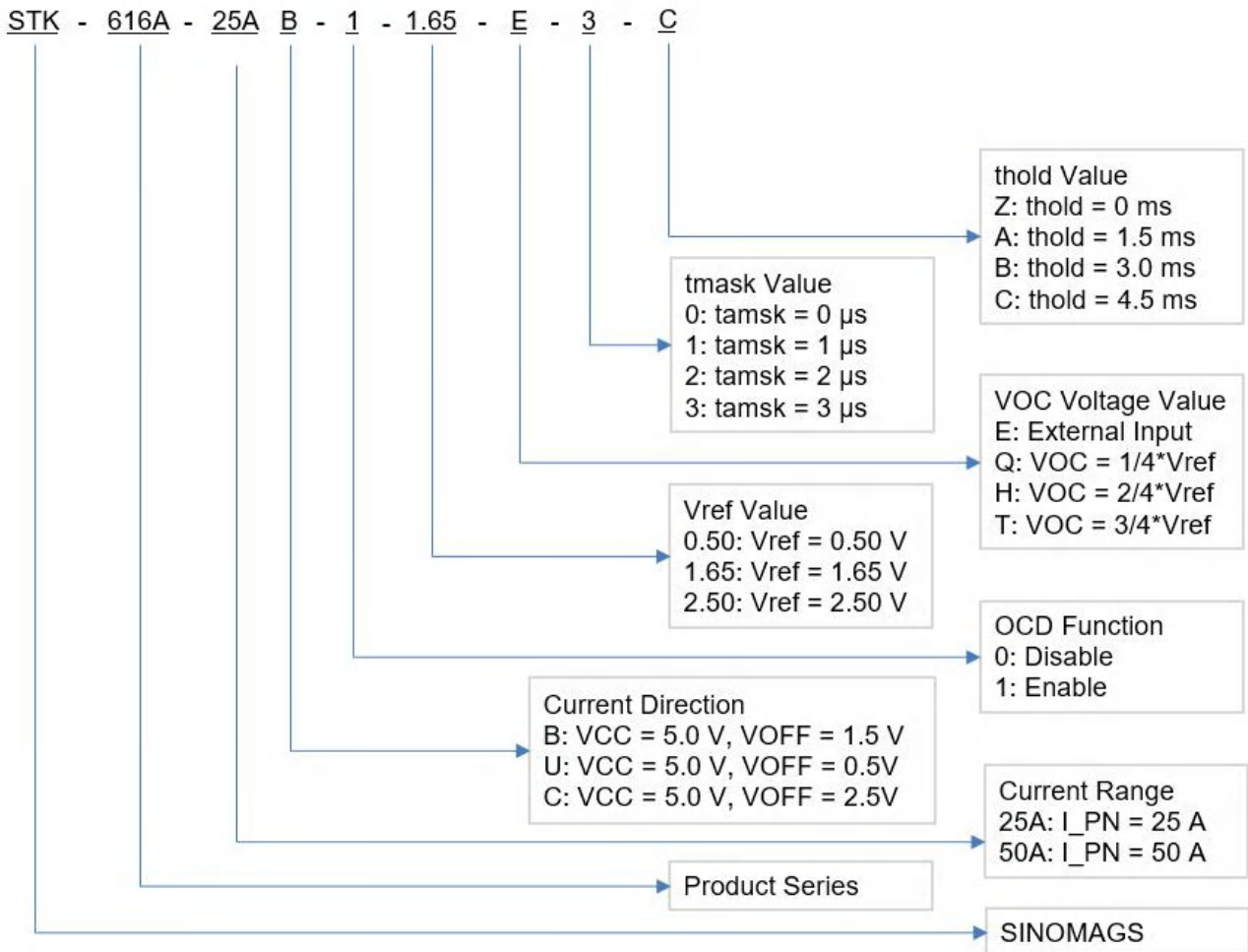

3. Temperature vs Current

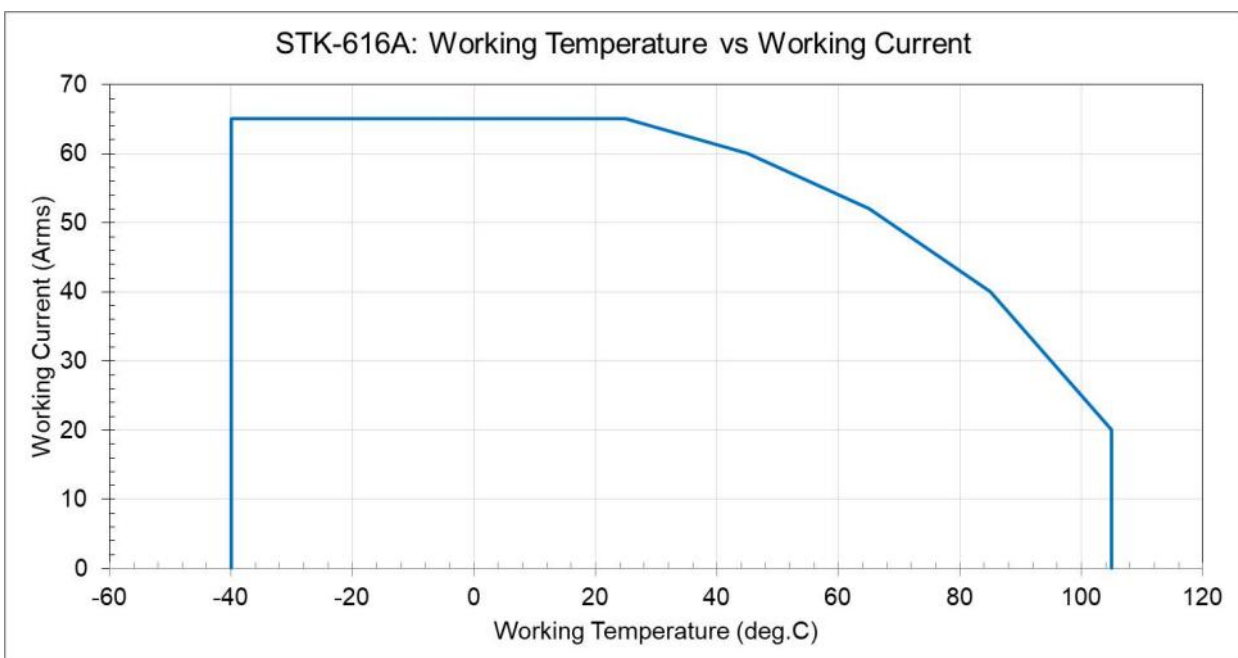

4. Electrical data

 Condition: $T_A = 25^{\circ}\text{C}$, $V_{CC} = 5\text{V}$

Parameter	Symbol	Unit	Min	Typ	Max	Comment
Primary nominal current	I_{pn}	A	-25		25	STK-616A-25AB
			-50		50	STK-616A-50AB
			-60		60	STK-616A-60AB
			-80		80	STK-616A-80AB
			-12		12	STK-616A-12AB
			-6		6	STK-616A-6AB
Primary current measuring range	I_{pm}	A	-27		27	STK-616A-25AB
			-54		54	STK-616A-50AB
			-110		110	STK-616A-60AB
			-86		86	STK-616A-80AB
			-14		14	STK-616A-12AB
			-7		7	STK-616A-6AB
Supply voltage	V_{CC}	V		5		
Current consumption	I_{CC}	mA		5	10	
Primary conductor resistance	R_{IP}	m Ω		0.3		
Reference voltage	V_{ref}	V	1.6	1.65	1.7	Internal use
			2.45	2.5	2.55	
Quiescent voltage	V_{off}	V	1.45	1.5	1.55	$V_{out} @ I_p = 0\text{A}$
			2.48	2.5	2.52	
Internal output resistance	R_{out}	Ω		1		V_{out}
GAIN, Note 1)	G_{th}	mV/A		48		STK-616A-25AB
				24		STK-616A-50AB
				12		STK-616A-60AB
				15		STK-616A-80AB
				100		STK-616A-12AB
				200		STK-616A-6AB
OCD range	VOC	V	0		3.3	Note 2)
FAULT error		%		5%		% of OCD
OCD Hysteresis	IHYS	%		10%		% of OCD
OCD Fault Mask	tmask	μs		2		Note 3)
OCD Fault Mask error	Tmask_error	ns		125		
OCD Fault Hold Time	thold	ms		4.5		Note 4)
Step response time	t_res	μs		1.5		@90% of I_{pn}
Frequency bandwidth (-3dB)	BW	kHz		150		No RC circuit

Noise	I_noise	mA rms		200		DC ~ 100 kHz
Non-linearity @ 25°C	ξ	% of I _{pn}		± 1.5		STK-616A-25AB
						STK-616A-50AB
						STK-616A-60AB
						STK-616A-80AB
						STK-616A-12AB
STK-616A-6AB						
Accuracy @ 25°C	X	% of I _{pn}		±1		@ 25°C
Thermal draft of G _{th} @ -40°C~85°C	GAIN_T	% of G _{th}	-1.0		1.0	Draft value related to the value @ 25°C
Thermal draft of V _{off} @ -40°C~85°C	Voff_T	mV	-10		10	
Total Accuracy @ -40°C~85°C	X_T	% of I _{pn}	-1.5		1.5	

Note

- 1) The gain of the sensor should be calibrated in software level if an accurate measuring is required.
- 2) The OCD trigger voltage = V_{ref} +/- V_{OC}. V_{OC} voltage can be input by external voltage, but V_{OC} shall be less than V_{cc} - 1.7 V. Refer the sections of "OCD function" & "General information on OCD" for more details.
- 3) The default time for OCD Fault Mask Time is 2 us, while it can be set as 0, 1, 2, 3 us per demand.
- 4) The default time for OCD Fault Hold Time is 4.5 ms, while it can be set as 0, 1.5, 3, 4.5 ms per demand.

5. Dimensions

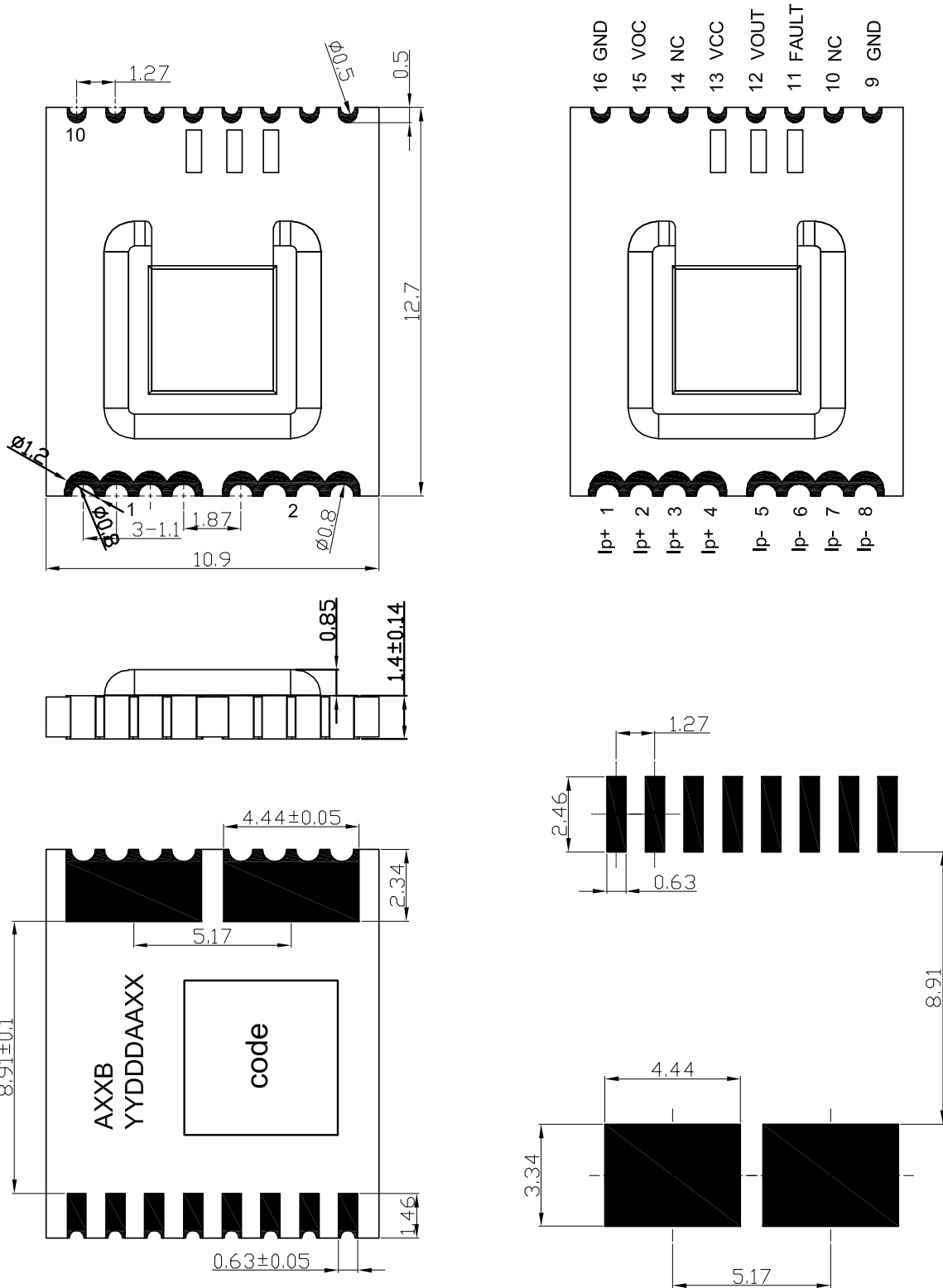

PCB Layout Reference View

6. Pin definitions

PIN	Symbol	Description
1,2,3,4	IP+	Primary conductor pin (+)
5,6,7,8	IP-	Primary conductor pin (-)
9,16	GND	Ground pin (GND)
10	VREF	Reference voltage
11	FAULT	Over current detection alarm output, the pin is open leakage output
12	VOUT	Sensor output pin
13	VCC	Power supply pin
14	NC	NC
15	VOC	Over current detection threshold input pin

7. PCB layout recommendation

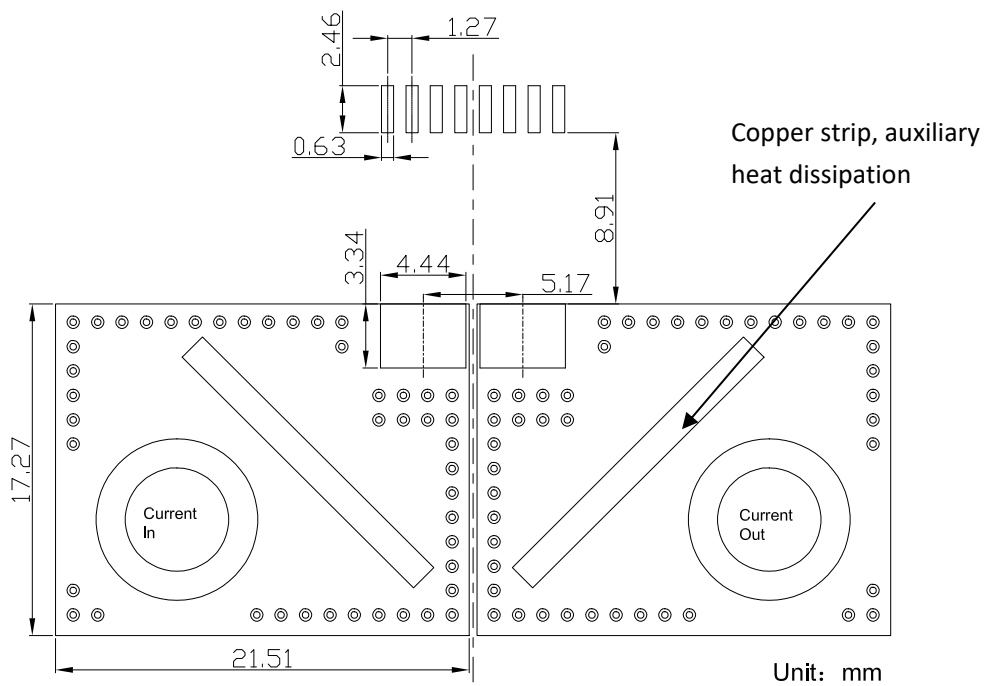

8. Frequency band width

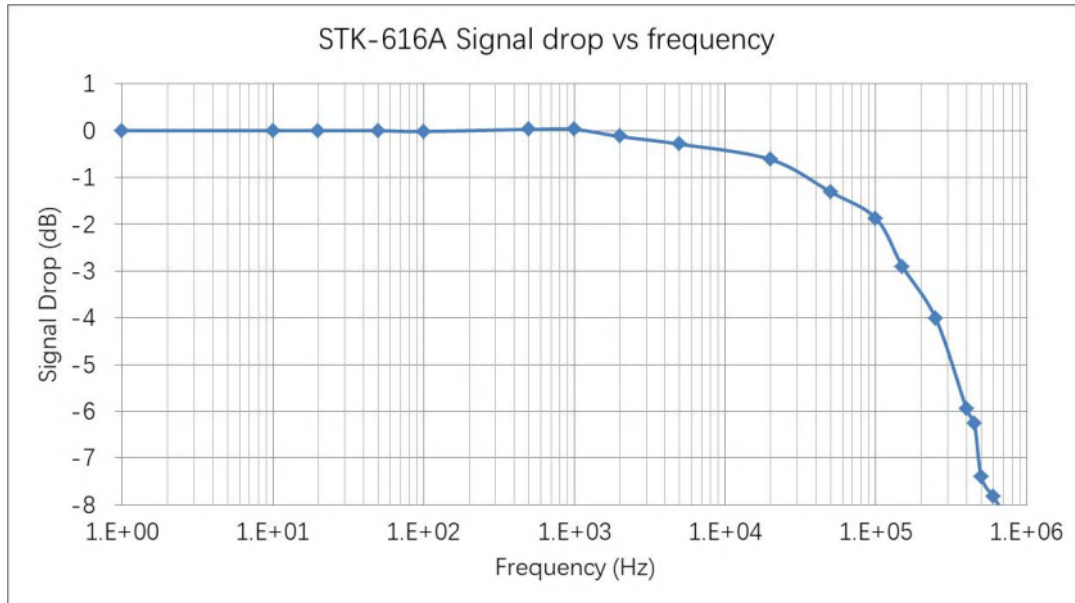

9. Step response time

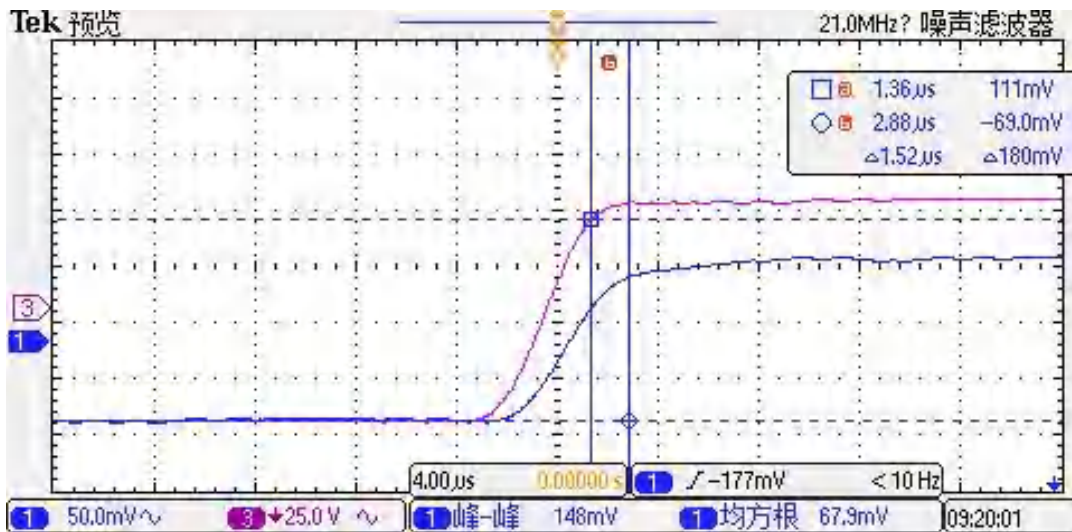

The typical frequency response of STK-616A current sensor. The response time from 90% of the primary current (blue) to 90% of the secondary output (green) is less than 1.5 μ s.

10. Block diagram

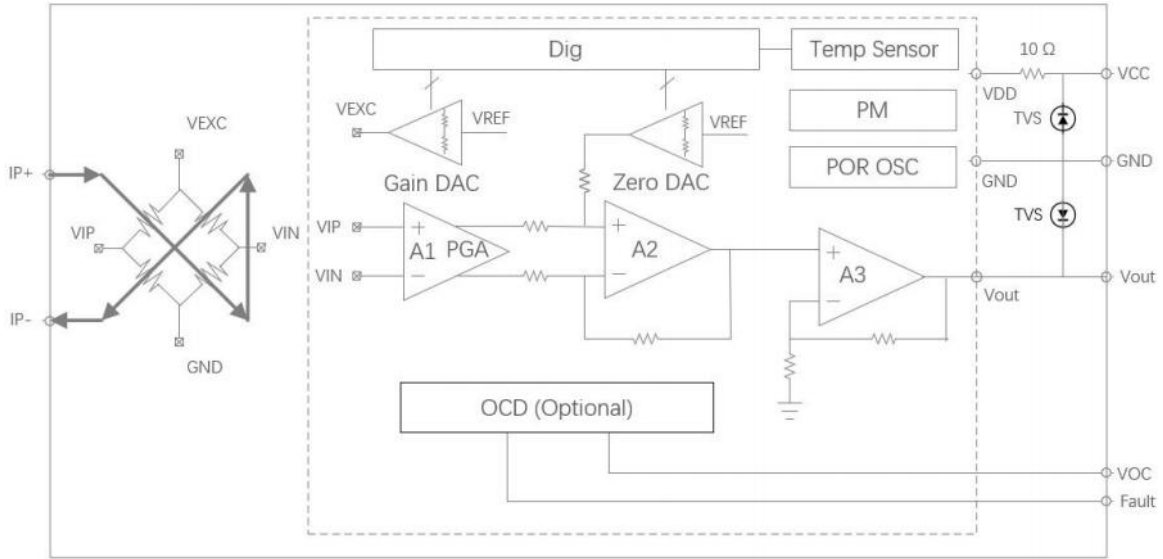

11. Typical application circuit

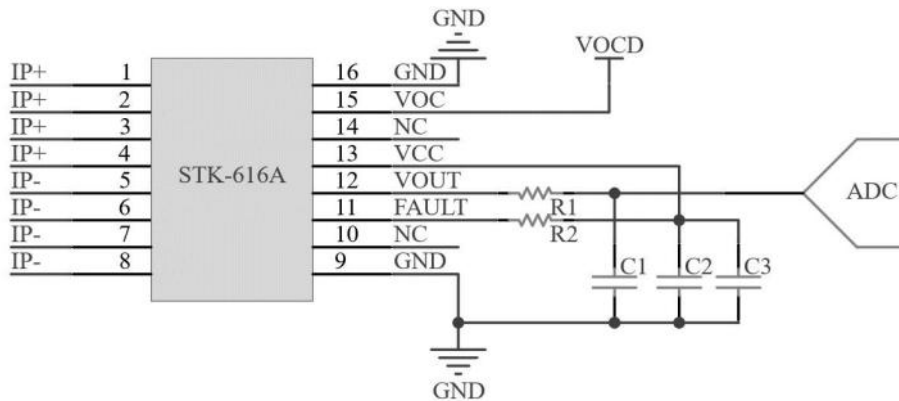

Remark: $R_2 = 10\text{ k}\Omega$, recommended $C_2 = 1\text{ }\mu\text{f}$, $C_3 = 10\text{ nf}$. 50 pf of C_1 does not affect the response speed of the chip. R_1 and C_1 constitute RC filter circuit ($f \approx 1/(2\pi RC)$). It should be considered that the band width of STK-616A is 150 kHz , so a RC setting of higher than 150 kHz will not achieve a band width higher than 150 kHz .

12. OCD voltage

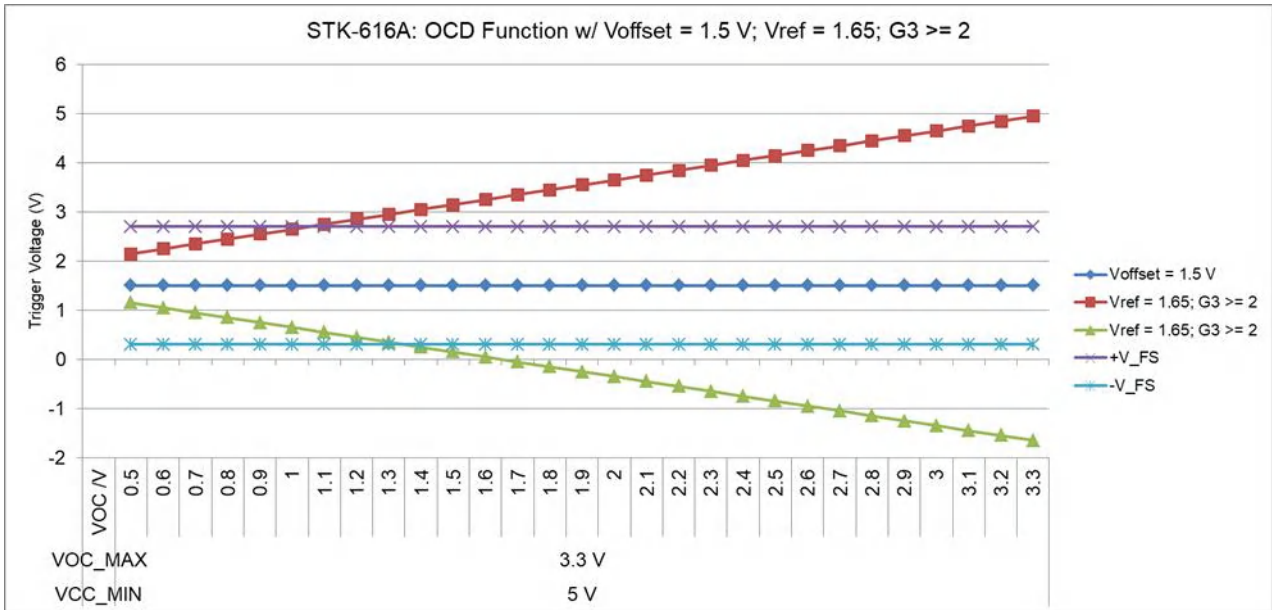

In the plot, the V_FS is output voltage @ +/-I_PN.

With conditions: $V_{cc} = 5.0\text{ V}$, $V_{ref} = 1.65\text{ V}$ (factory setting), $G3 \cong 2$ (factory setting), $V_{off} = 1.5\text{ V}$, the STK-616A current sensor can provide a protection trigger current higher than I_{pn} .

The trigger voltage = $V_{ref} \pm V_{OC}$, here, $V_{OC} \cong V_{cc} - 1.7\text{ V}$.

13. OCD function for STK-616A-25A

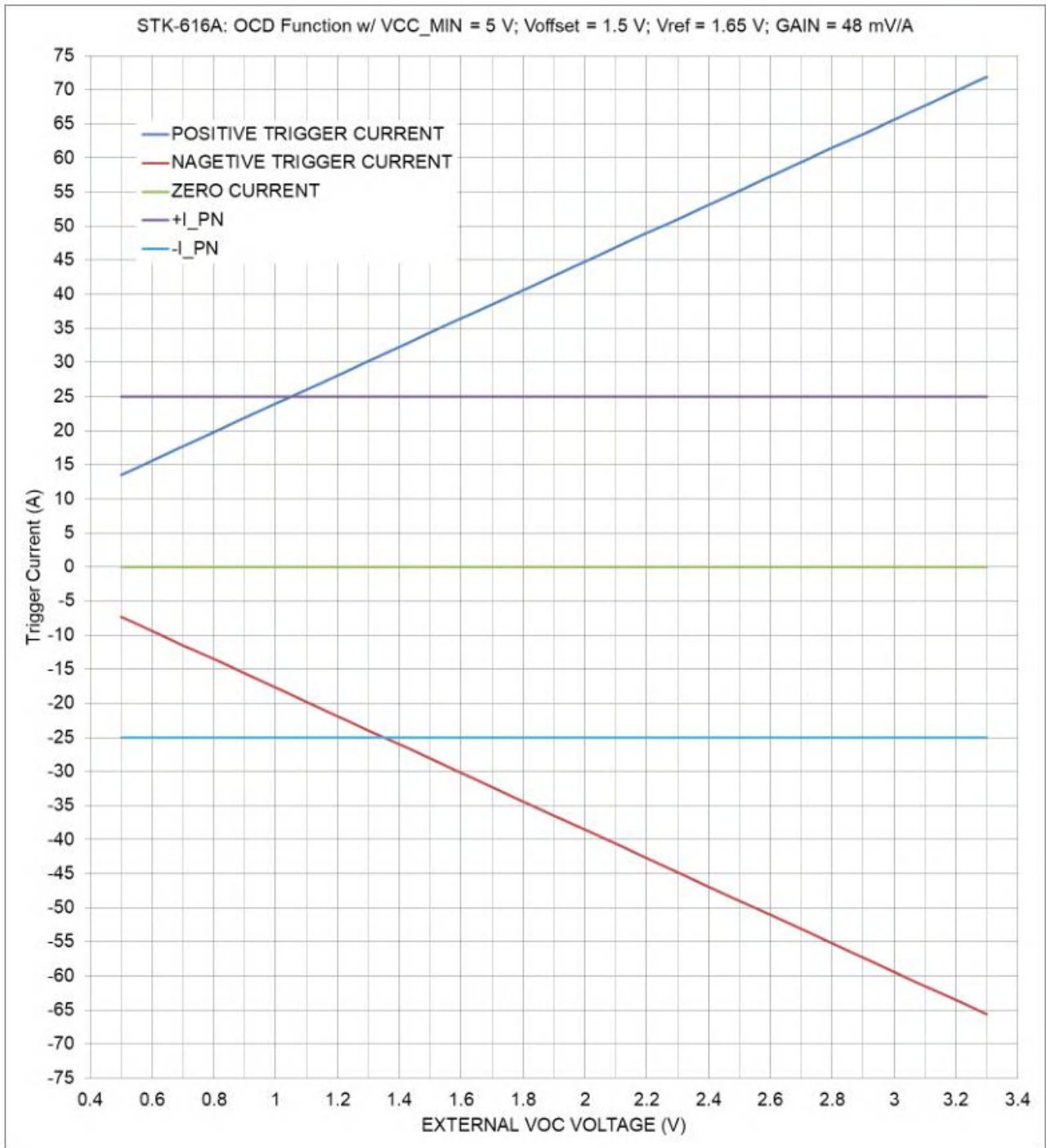

Based on the setting for STK-616A, since the Quiescent voltage, Voff of 1.5 V, is not the same as the reference voltage, Vref of 1.65 V, the trigger current is not equivalent for positive and negative current.

14. OCD function for STK-616A-50A

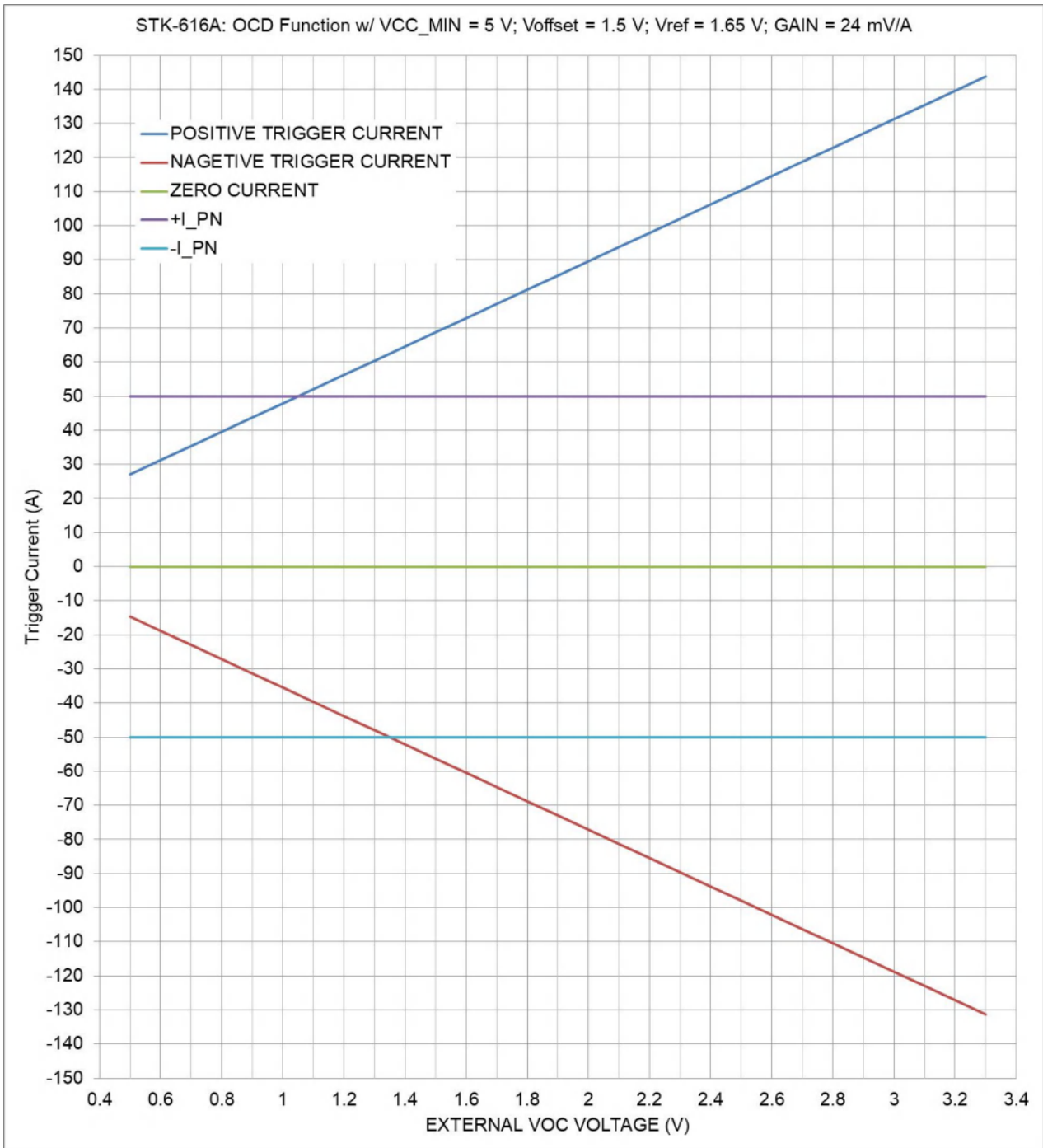

Based on the setting for STK-616A, since the Quiescent voltage, Voff of 1.5 V, is not the same as the reference voltage, Vref of 1.65 V, the trigger current is not equivalent for positive and negative current.

15. OCD function for STK-616A-80A

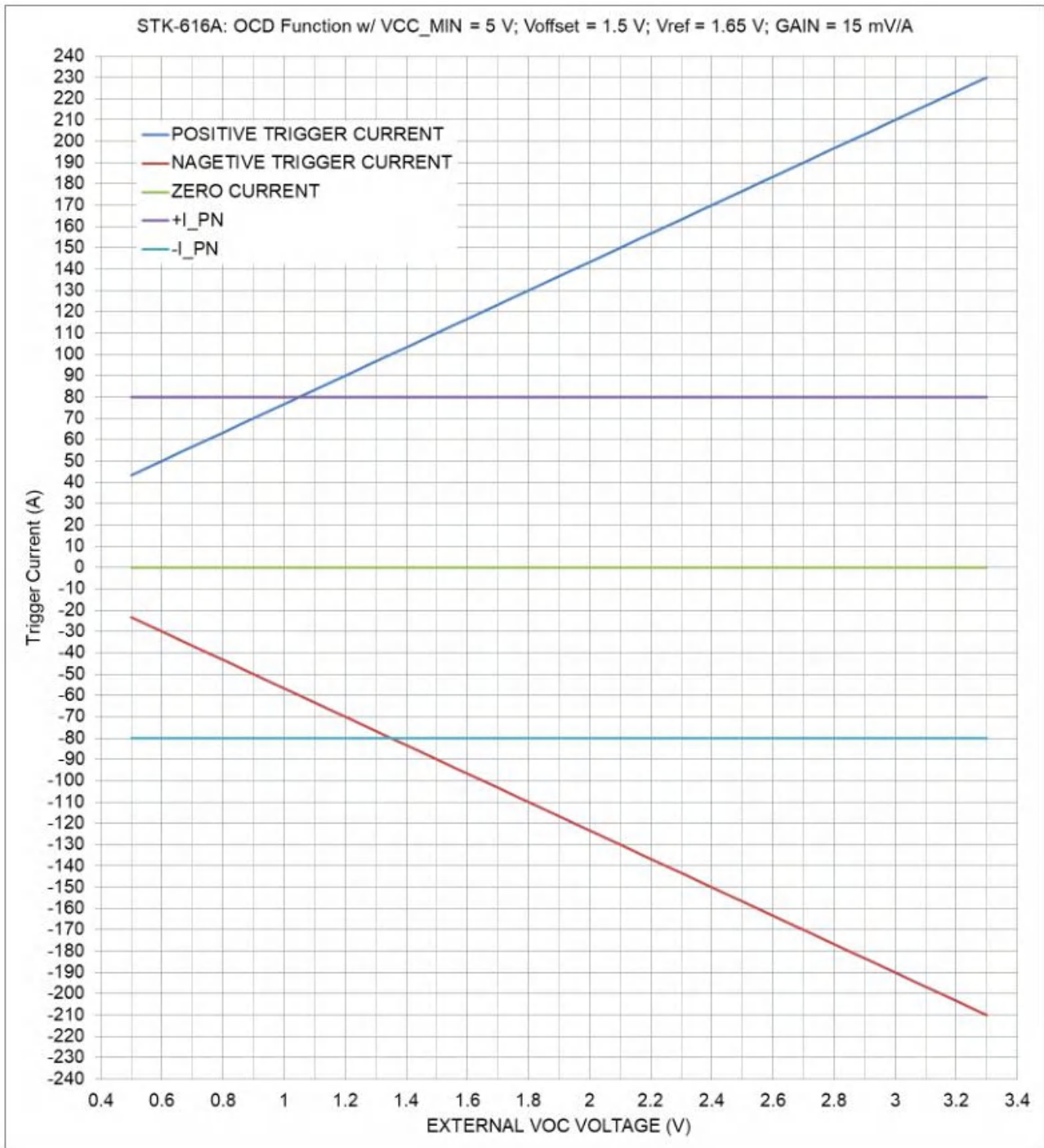

Based on the setting for STK-616A, since the Quiescent voltage, Voff of 1.5 V, is not the same as the reference voltage, Vref of 1.65 V, the trigger current is not equivalent for positive and negative current.

16. General information on OCD

This section describes the general information on OCD function, the specific functions, which are not listed in the section of “electrical data”, can be defined per request.

Since the trigger voltage is set after the second amplifier, the OCD function supports that the trigger current can be higher than I_{pn} . The trigger voltage can be defined:

- Trigger voltage = $V_{ref} \pm V_{OC}$, when $V_{ref} = 2.5\text{ V}$ or 1.65 V ;
- Trigger voltage = $V_{ref} + 8 \cdot V_{OC}$, when $V_{ref} = 0.5\text{ V}$;
- $V_{OC} \cong V_{cc} - 1.7\text{ V}$;

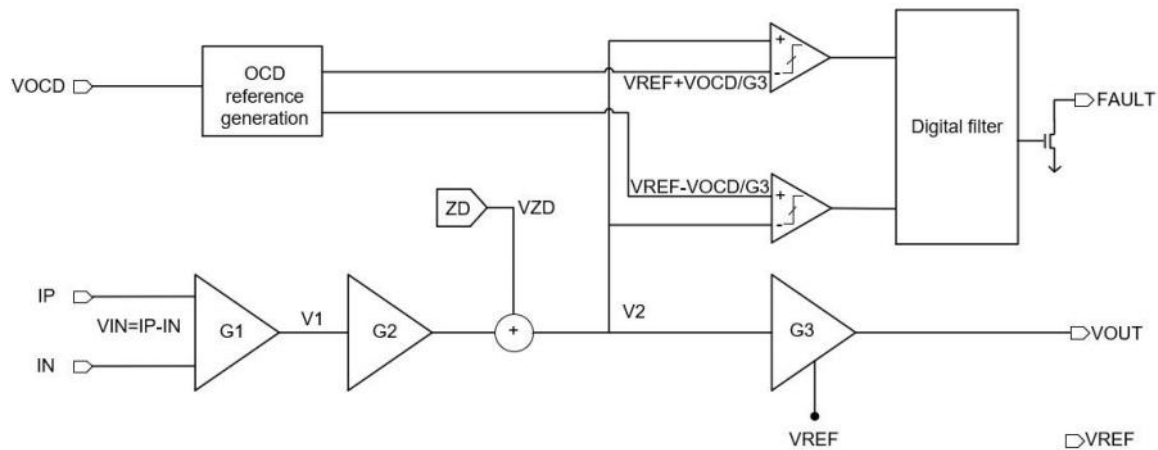

Functional Block Diagram on OCD function when $V_{ref} = 2.5\text{ V}$ or 1.65 V .

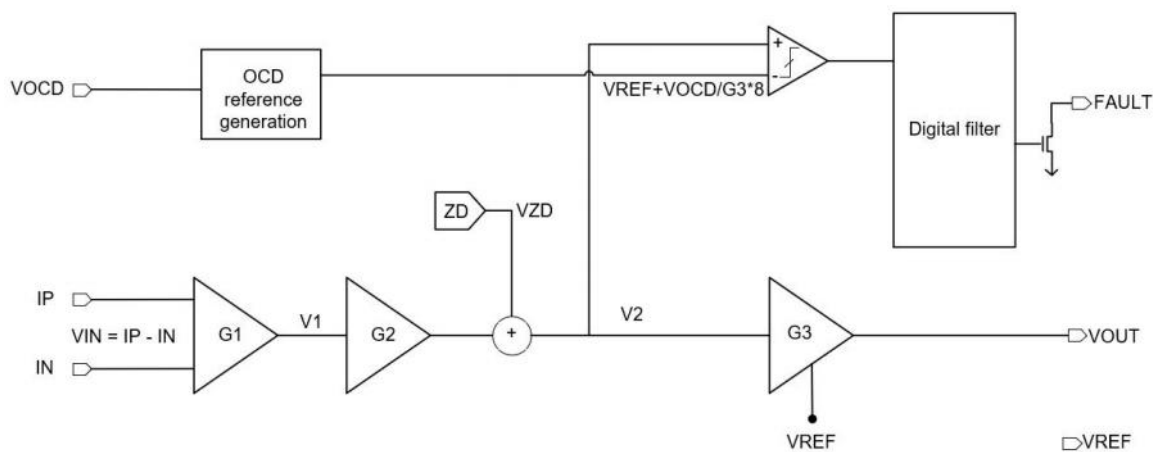

Functional Block Diagram on OCD function when $V_{ref} = 0.5\text{ V}$.

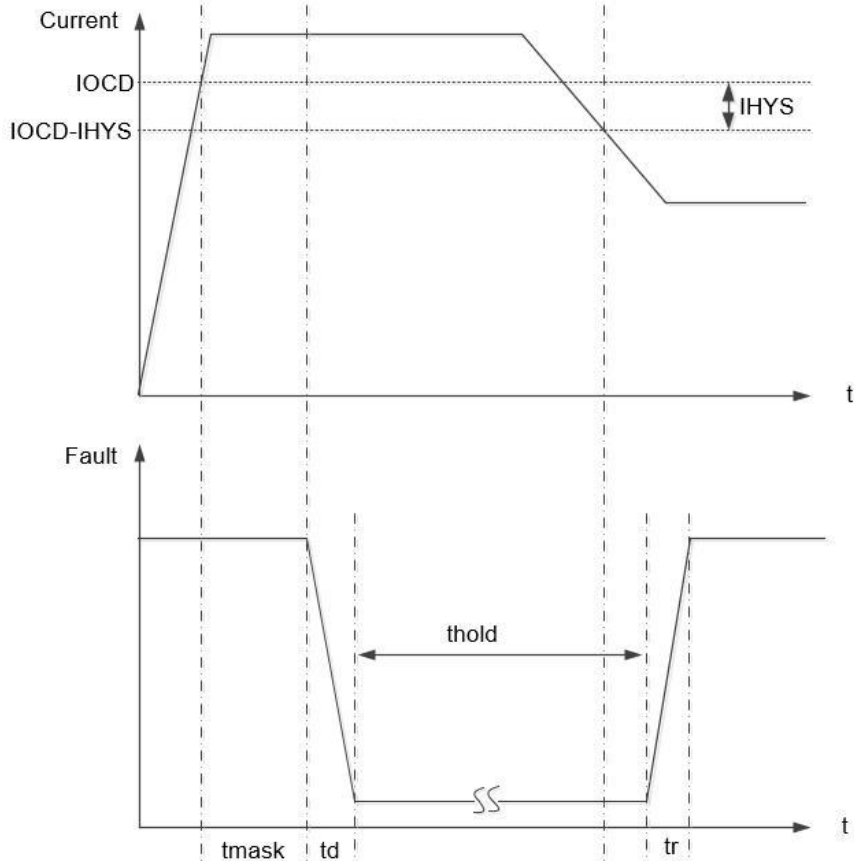

The above plot shows the definition on the time in OCD function. The typical value for t_d & t_r is that $t_d = 2$ ns, and $t_r = 91$ ns with setting as show in the section of "typical application circuit".

Supply Vcc / V	VOC Setting			Trigger Voltage		REMARK	
	Vref Voltage / V	Factor	VOC Value	Positive	Negative		
5.0	2.5		External	External	External	Necessary Conditions: (1) $G3 \geq 2$, factory setting (2) $VOC \leq Vcc - 1.7$ V The Trigger Voltage = (1) $Vref \pm Factor * VOC$, when $Vref = 2.5$ V or 1.65 V (2) $Vref + Factor * VOC$, when $Vref = 0.5$ V	
		1	$1/4 * Vref$	3.125 V	1.875 V		
		1	$2/4 * Vref$	3.75 V	1.25 V		
	1.65			External	External		External
		1	$1/4 * Vref$	2.0625 V	1.2375 V		
		1	$2/4 * Vref$	2.475 V	0.825 V		
	0.5			External	External		-
		8	$1/4 * Vref$	1.5 V	-		
		8	$2/4 * Vref$	2.5 V	-		
	3.3	1.65		External	External		External
			1	$1/4 * Vref$	2.0625 V		1.2375 V
			1	$2/4 * Vref$	2.475 V		0.825 V
0.5			External	External	-		
		8	$1/4 * Vref$	1.5 V	-		
		8	$2/4 * Vref$	2.5 V	-		