

## CURRENT SENSOR

---

PRODUCT SERIES: SFG-X.XP/N1

PRODUCT PART NUMBER: SFG-0.3P/N1, SFG-0.6P/N1, SFG-1.0P/N1  
SFG-1.5P/N1, SFG-2.0P/N1, SFG-3.0P/N1,  
SFG-5.0P/N1

Version: Ver1.1



---

## CONTENT

1.	Description .....	2
2.	Absolute parameter: SFG-P/N1 .....	3
3.	Electrical data: SFG-0.3P/N1 .....	4
4.	Electrical data: SFG-0.6P/N1 .....	5
5.	Electrical data: SFG-1.0P/N1 .....	6
6.	Electrical data: SFG-1.5P/N1 .....	7
7.	Electrical data: SFG-2.0P/N1 .....	8
8.	Electrical data: SFG-3.0P/N1 .....	9
9.	Electrical data: SFG-5.0P/N1 .....	10
10.	SFG- P/N1 Dimensions .....	11

## 1. Description

### Features

- Closed loop (compensated) current transducer
- Voltage output
- Insulation voltage for 5 kVAC
- Single supply voltage
- PCB mounting.

### Advantages

- High accuracy
- High overload capability
- High insulation capability
- High separation ability
- Low temperature drift
- Degauss and test functions

### Applications

- Residual current measurement
- Leakage current measurement in PV inverters
- First human contact protection of PV arrays
- Failure detection in power sources
- Leakage current detection in stacked DC sources
- Communication power

## 2. Absolute parameter: SFG-P/N1

### Absolute maximum ratings

Parameter	Symbol	Unit	Value
Maximum Supply voltage	$V_{C \max}$	V	7
Maximum Primary conductor temperature	$T_{B \max}$	°C	110
Maximum overload capability (100 $\mu$ s, 500 A/ $\mu$ s)	$\hat{I}_{P \max}$	A	3300

### Ratings

Parameter	Symbol	Unit	Value
Primary involved potential		V AC/DC	600
Max surrounding air temperature	$T_A$	°C	105
Secondary supply voltage	$U_C$	V DC	5
Output voltage	$V_{out}$	V	0 to 5

### Isolation parameters

Parameter	Symbol	Unit	Value	Remark
RMS voltage for AC test 50 Hz/1 min	$V_d$	kV	5	
Impulse withstand voltage 1.2/50 $\mu$ s	$V_w$	kV	10.1	
Clearance distance (pri. –sec.)	$d_{Cl}$	mm	11	Shortest distance through air
Creepage distance (pri. –sec.)	$d_{Cp}$	mm	11	Shortest path along device body
Comparative tracking index	CTI	V	600	
Application example	-	V	600	Reinforced insulation, CAT III, PD2 non uniform field
Application example	-	V	1000	Basic insulation, CAT III, PD2 non uniform field

### Environmental and mechanical characteristics

Parameter	Symbol	Unit	Min	Typ	Max	Comment
Ambient operating temperature	$T_A$	°C	-40		105	
Ambient storage temperature	$T_S$	°C	-40		105	
Mass	m	g		50		
standard	EN 50178, IEC 61010, UL 508					

### 3. Electrical data: SFG-0.3P/N1

At  $T_A = 25\text{ }^\circ\text{C}$ ,  $V_C = 5\text{ V}$ .

Parameters	Symbol	Unit	Min	Typ	Max	Remark
Primary nominal residual rms current	$I_{PN}$	A		0.3		
Primary residual current, measuring range	$I_{PM}$	A	-0.5		0.5	
Supply voltage	$V_C$	V	4.75	5	5.25	
Current consumption	$I_C$	mA		17.5	21.6	$I_P(\text{mA}) / N_a$ $N_a = 1000\text{ turns}$ - 40°C ... 105°C
Output voltage referred to $V_{ref}$ (Test current)	$V_{out}$	V	0.7	1.2	1.7	
Reference voltage @ $I_P = 0$	$V_{ref}$	V	2.495	2.5	2.505	Internal reference
External reference voltage	$V_{REF}$	V	2.3		4	Internal reference of $V_{ref}$ input = 499 $\Omega$
Electrical offset current referred to primary	$I_{OE}$	mA	-24	7	24	
Temperature coefficient of VOE @ $I_P = 0$	$TCV_{OE}$	ppm/K			$\pm 570$	ppm/K of 2.5 V -40 ... 105 °C
Theoretical sensitivity	$G_{th}$	V/A		4		
Sensitivity error	$\epsilon_G$	%	-1.6	0.5	1.6	$R_L > 500\text{ k}\Omega$
Temperature coefficient of G	$TCG$	ppm/K			$\pm 400$	- 40°C ... 105°C
Linearity error	$\epsilon_L$	%		0.5	1	
Number of turns (test winding)	$N_T$			20		$R_L > 500\text{ k}\Omega$ , $di/dt > 5\text{ A}/\mu\text{s}$
Reaction time @ 10 % of $I_{PRN}$	$t_{ra}$	$\mu\text{s}$		7		$R_L > 500\text{ k}\Omega$ , $di/dt > 5\text{ A}/\mu\text{s}$
Step response time to 90 % of $I_{PN}$	$t_r$	$\mu\text{s}$		50		$R_L > 500\text{ k}\Omega$ , $di/dt > 5\text{ A}/\mu\text{s}$
Frequency bandwidth (-3dB)	BW	kHz		15		$R_L > 500\text{ k}\Omega$
Noise(1 Hz ~ 10 kHz)	$V_{no}$	mV rms		10		$R_L > 500\text{ k}\Omega$
Accuracy@ $I_{PN}$ @ $T_A = 25\text{ }^\circ\text{C}$	$X_{25C}$	% of $I_{PN}$		$\pm 1.9$		
Accuracy@ $I_{PN}$ @ $T_A = 105\text{ }^\circ\text{C}$	$X_{105C}$	% of $I_{PN}$		$\pm 3.2$		

#### 4. Electrical data: SFG-0.6P/N1

At  $T_A = 25\text{ }^\circ\text{C}$ ,  $V_C = 5\text{ V}$ .

Parameters	Symbol	Unit	Min	Typ	Max	Remark
Primary nominal residual rms current	$I_{PN}$	A		0.6		
Primary residual current, measuring range	$I_{PM}$	A	-0.85		0.85	
Supply voltage	$V_C$	V	4.75	5	5.25	
Current consumption	$I_C$	mA		17.5	21.6	$I_P(\text{mA}) / N_a$ $N_a = 1000\text{ turns}$ - $40\text{ }^\circ\text{C} \dots 105\text{ }^\circ\text{C}$
Output voltage referred to $V_{ref}$ (Test current)	$V_{out}$	V	0.4	0.75	1.1	
Reference voltage @ $I_P = 0$	$V_{ref}$	V	2.495	2.5	2.505	Internal reference
External reference voltage	$V_{REF}$	V	2.3		4	Internal reference of $V_{ref}$ input = $499\text{ }\Omega$
Electrical offset current referred to primary	$I_{OE}$	mA	-24	4.2	24	
Temperature coefficient of VOE @ $I_P = 0$	$TCV_{OE}$	ppm/K			$\pm 520$	ppm/K of 2.5 V - $40 \dots 105\text{ }^\circ\text{C}$
Theoretical sensitivity	$G_{th}$	V/A		2.476		
Sensitivity error	$\epsilon_G$	%	-0.7	0.5	0.7	$R_L > 500\text{ k}\Omega$
Temperature coefficient of G	$TCG$	ppm/K			$\pm 100$	- $40\text{ }^\circ\text{C} \dots 105\text{ }^\circ\text{C}$
Linearity error	$\epsilon_L$	%		0.4	1.3	
Number of turns (test winding)	$N_T$			20		$R_L > 500\text{ k}\Omega$ , $di/dt > 5\text{ A}/\mu\text{s}$
Reaction time @ 10 % of $I_{PRN}$	$t_{ra}$	$\mu\text{s}$		5		$R_L > 500\text{ k}\Omega$ , $di/dt > 5\text{ A}/\mu\text{s}$
Step response time to 90 % of $I_{PN}$	$t_r$	$\mu\text{s}$		30		$R_L > 500\text{ k}\Omega$ , $di/dt > 5\text{ A}/\mu\text{s}$
Frequency bandwidth (-3dB)	BW	kHz		15		$R_L > 500\text{ k}\Omega$
Noise(1 Hz ~ 10 kHz)	$V_{no}$	mV rms		10		$R_L > 500\text{ k}\Omega$
Accuracy@ $I_{PN}$ @ $T_A = 25\text{ }^\circ\text{C}$	$X_{25\text{ }^\circ\text{C}}$	% of $I_{PN}$		$\pm 1.9$		
Accuracy@ $I_{PN}$ @ $T_A = 105\text{ }^\circ\text{C}$	$X_{105\text{ }^\circ\text{C}}$	% of $I_{PN}$		$\pm 3.2$		

## 5. Electrical data: SFG-1.0P/N1

At  $T_A = 25\text{ }^\circ\text{C}$ ,  $V_C = 5\text{ V}$ .

Parameters	Symbol	Unit	Min	Typ	Max	Remark
Primary nominal residual rms current	$I_{PN}$	A		1		
Primary residual current, measuring range	$I_{PM}$	A	-1.7		1.7	
Supply voltage	$V_C$	V	4.75	5	5.25	
Current consumption	$I_C$	mA		17.5	21.6	$I_P(\text{mA}) / N_a$ $N_a = 1000\text{ turns}$ - $40\text{ }^\circ\text{C} \dots 105\text{ }^\circ\text{C}$
Output voltage referred to $V_{ref}$ (Test current)	$V_{out}$	V	0.2	0.35	0.5	
Reference voltage @ $I_P = 0$	$V_{ref}$	V	2.495	2.5	2.505	Internal reference
External reference voltage	$V_{REF}$	V	2.3		4	Internal reference of $V_{ref}$ input = $499\text{ }\Omega$
Electrical offset current referred to primary	$I_{OE}$	mA	-24	7	24	
Temperature coefficient of VOE @ $I_P = 0$	$TCV_{OE}$	ppm/K		$\pm 50$	$\pm 500$	ppm/K of 2.5 V - $40 \dots 105\text{ }^\circ\text{C}$
Theoretical sensitivity	$G_{th}$	V/A		1.2		
Sensitivity error	$\epsilon_G$	%	-1.6	0.5	1.6	$R_L > 500\text{ k}\Omega$
Temperature coefficient of G	$TCG$	ppm/K			$\pm 400$	- $40\text{ }^\circ\text{C} \dots 105\text{ }^\circ\text{C}$
Linearity error	$\epsilon_L$	%		0.5	1	
Number of turns (test winding)	$N_T$			20		$R_L > 500\text{ k}\Omega$ , $di/dt > 5\text{ A}/\mu\text{s}$
Reaction time @ 10 % of $I_{PRN}$	$t_{ra}$	$\mu\text{s}$		7		$R_L > 500\text{ k}\Omega$ , $di/dt > 5\text{ A}/\mu\text{s}$
Step response time to 90 % of $I_{PN}$	$t_r$	$\mu\text{s}$		50		$R_L > 500\text{ k}\Omega$ , $di/dt > 5\text{ A}/\mu\text{s}$
Frequency bandwidth (-3dB)	BW	kHz		15		$R_L > 500\text{ k}\Omega$
Noise(1 Hz ~ 10 kHz)	$V_{no}$	mV rms		10		$R_L > 500\text{ k}\Omega$
Accuracy@ $I_{PN}$ @ $T_A = 25\text{ }^\circ\text{C}$	$X_{25\text{ }^\circ\text{C}}$	% of $I_{PN}$		$\pm 1.9$		
Accuracy@ $I_{PN}$ @ $T_A = 105\text{ }^\circ\text{C}$	$X_{105\text{ }^\circ\text{C}}$	% of $I_{PN}$		$\pm 3.2$		

## 6. Electrical data: SFG-1.5P/N1

At  $T_A = 25\text{ }^\circ\text{C}$ ,  $V_C = 5\text{ V}$ .

Parameters	Symbol	Unit	Min	Typ	Max	Remark
Primary nominal residual rms current	$I_{PN}$	A		1.5		
Primary residual current, measuring range	$I_{PM}$	A	-2		2	
Supply voltage	$V_C$	V	4.75	5	5.5	
Current consumption	$I_C$	mA		17.5	21.6	$I_P(\text{mA}) / N_a$ $N_a = 1000\text{ turns}$ - 40°C ... 105°C
Output voltage referred to $V_{ref}$ (Test current)	$V_{out}$	V	0.12		0.5	
Reference voltage @ $I_P = 0$	$V_{ref}$	V	2.495	2.5	2.505	Internal reference
External reference voltage	$V_{REF}$	V	2.3		4	Internal reference of $V_{ref}$ input = 499 $\Omega$
Electrical offset current referred to primary	$I_{OE}$	mA	-30	4.2	30	
Temperature coefficient of VOE @ $I_P = 0$	$TCV_{OE}$	ppm/K			$\pm 570$	ppm/K of 2.5 V -40 ... 105 °C
Theoretical sensitivity	$G_{th}$	V/A		0.8		
Sensitivity error	$\epsilon_G$	%	-1.6	0.5	1.6	$R_L > 500\text{ k}\Omega$
Temperature coefficient of G	$TCG$	ppm/K			$\pm 400$	- 40°C ... 105°C
Linearity error	$\epsilon_L$	%		0.5	1	
Number of turns (test winding)	$N_T$			20		$R_L > 500\text{ k}\Omega$ , $di/dt > 5\text{ A}/\mu\text{s}$
Reaction time @ 10 % of $I_{PRN}$	$t_{ra}$	$\mu\text{s}$		5		$R_L > 500\text{ k}\Omega$ , $di/dt > 5\text{ A}/\mu\text{s}$
Step response time to 90 % of $I_{PN}$	$t_r$	$\mu\text{s}$		50		$R_L > 500\text{ k}\Omega$ , $di/dt > 5\text{ A}/\mu\text{s}$
Frequency bandwidth (-3dB)	$BW$	kHz		15		$R_L > 500\text{ k}\Omega$
Noise(1 Hz ~ 10 kHz)	$V_{no}$	mV rms		10		$R_L > 500\text{ k}\Omega$
Accuracy@ $I_{PN}$ @ $T_A = 25\text{ }^\circ\text{C}$	$X_{25c}$	% of $I_{PN}$		$\pm 1.9$		
Accuracy@ $I_{PN}$ @ $T_A = 105\text{ }^\circ\text{C}$	$X_{105c}$	% of $I_{PN}$		$\pm 3.2$		



## 7. Electrical data: SFG-2.0P/N1

At  $T_A = 25\text{ }^\circ\text{C}$ ,  $V_C = 5\text{ V}$ .

Parameters	Symbol	Unit	Min	Typ	Max	Remark
Primary nominal residual rms current	$I_{PN}$	A		2.0		
Primary residual current, measuring range	$I_{PM}$	A	-3.0		3.0	
Supply voltage	$V_C$	V	4.75	5	5.5	
Current consumption	$I_C$	mA		17.5	21.6	$I_P(\text{mA}) / N_a$ $N_a = 1000\text{ turns}$ - $40\text{ }^\circ\text{C} \dots 105\text{ }^\circ\text{C}$
Reference voltage @ $I_P = 0$	$V_{ref}$	V	2.495	2.5	2.505	Internal reference
External reference voltage	$V_{REF}$	V	2.3		4	Internal reference of $V_{ref}$ input = $499\ \Omega$
Electrical offset current referred to primary	$I_{OE}$	mA	-24	7	24	
Temperature coefficient of VOE @ $I_P = 0$	$TCV_{OE}$	ppm/K			$\pm 570$	ppm/K of 2.5 V - $40 \dots 105\text{ }^\circ\text{C}$
Theoretical sensitivity	$G_{th}$	V/A		0.66		
Sensitivity error	$\epsilon_G$	%	-1.6	0.5	1.6	$R_L > 500\text{ k}\Omega$
Temperature coefficient of G	$TCG$	ppm/K		$\pm 400$		- $40\text{ }^\circ\text{C} \dots 105\text{ }^\circ\text{C}$
Linearity error	$\epsilon_L$	%		0.5	1	
Number of turns (test winding)	$N_T$			20		$R_L > 500\text{ k}\Omega$ , $di/dt > 5\text{ A}/\mu\text{s}$
Reaction time @ 10 % of $I_{PRN}$	$t_{ra}$	$\mu\text{s}$		5		$R_L > 500\text{ k}\Omega$ , $di/dt > 5\text{ A}/\mu\text{s}$
Step response time to 90 % of $I_{PN}$	$t_r$	$\mu\text{s}$		50		$R_L > 500\text{ k}\Omega$ , $di/dt > 5\text{ A}/\mu\text{s}$
Frequency bandwidth (-3dB)	$BW$	kHz		15		$R_L > 500\text{ k}\Omega$
Noise(1 Hz ~ 10 kHz)	$V_{no}$	mV rms		5		$R_L > 500\text{ k}\Omega$
Accuracy@ $I_{PN}$ @ $T_A = 25\text{ }^\circ\text{C}$	$X_{25c}$	% of $I_{PN}$		$\pm 1.9$		
Accuracy@ $I_{PN}$ @ $T_A = 105\text{ }^\circ\text{C}$	$X_{105c}$	% of $I_{PN}$		$\pm 3.2$		

## 8. Electrical data: SFG-3.0P/N1

At  $T_A = 25\text{ }^\circ\text{C}$ ,  $V_C = 5\text{ V}$ .

Parameters	Symbol	Unit	Min	Typ	Max	Remark
Primary nominal residual rms current	$I_{PN}$	A		3.0		
Primary residual current, measuring range	$I_{PM}$	A	-5		5	
Supply voltage	$V_C$	V	4.75	5	5.5	
Current consumption	$I_C$	mA		17.5	21.6	$I_P(\text{mA}) / N_a$ $N_a = 1000\text{ turns}$ - $40\text{ }^\circ\text{C} \dots 105\text{ }^\circ\text{C}$
Reference voltage @ $I_P = 0$	$V_{ref}$	V	2.495	2.5	2.505	Internal reference
External reference voltage	$V_{REF}$	V	2.3		4	Internal reference of $V_{ref}$ input = $499\ \Omega$
Electrical offset current referred to primary	$I_{OE}$	mA	-24	7	24	
Temperature coefficient of VOE @ $I_P = 0$	$TCV_{OE}$	ppm/K			$\pm 570$	ppm/K of 2.5 V - $40 \dots 105\text{ }^\circ\text{C}$
Theoretical sensitivity	$G_{th}$	V/A		0.4		
Sensitivity error	$\epsilon_G$	%	-1.6	0.5	1.6	$R_L > 500\text{ k}\Omega$
Temperature coefficient of G	$TCG$	ppm/K			$\pm 400$	- $40\text{ }^\circ\text{C} \dots 105\text{ }^\circ\text{C}$
Linearity error	$\epsilon_L$	%		0.5	1	
Number of turns (test winding)	$N_T$			20		$R_L > 500\text{ k}\Omega$ , $di/dt > 5\text{ A}/\mu\text{s}$
Reaction time @ 10 % of $I_{PRN}$	$t_{ra}$	$\mu\text{s}$		5		$R_L > 500\text{ k}\Omega$ , $di/dt > 5\text{ A}/\mu\text{s}$
Step response time to 90 % of $I_{PN}$	$t_r$	$\mu\text{s}$		50		$R_L > 500\text{ k}\Omega$ , $di/dt > 5\text{ A}/\mu\text{s}$
Frequency bandwidth (-3dB)	$BW$	kHz		15		$R_L > 500\text{ k}\Omega$
Noise(1 Hz ~ 10 kHz)	$V_{no}$	mV rms		10		$R_L > 500\text{ k}\Omega$
Accuracy@ $I_{PN}$ @ $T_A = 25\text{ }^\circ\text{C}$	$X_{25c}$	% of $I_{PN}$		$\pm 1.9$		
Accuracy@ $I_{PN}$ @ $T_A = 105\text{ }^\circ\text{C}$	$X_{105c}$	% of $I_{PN}$		$\pm 3.2$		

## 9. Electrical data: SFG-5.0P/N1

At  $T_A = 25\text{ }^\circ\text{C}$ ,  $V_C = 5\text{ V}$ .

Parameters	Symbol	Unit	Min	Typ	Max	Remark
Primary nominal residual rms current	$I_{PN}$	A		5		
Primary residual current, measuring range	$I_{PM}$	A	-10		10	
Supply voltage	$V_C$	V	4.75	5	5.5	
Current consumption	$I_C$	mA		17.5	21.6	$I_P(\text{mA}) / N_a$ $N_a = 1000\text{ turns}$ - $40\text{ }^\circ\text{C} \dots 105\text{ }^\circ\text{C}$
Reference voltage @ $I_P = 0$	$V_{ref}$	V	2.495	2.5	2.505	Internal reference
External reference voltage	$V_{REF}$	V	2.3		4	Internal reference of $V_{ref}$ input = $499\ \Omega$
Electrical offset current referred to primary	$I_{OE}$	mA	-24	7	24	
Temperature coefficient of VOE @ $I_P = 0$	$TCV_{OE}$	ppm/K			$\pm 570$	ppm/K of 2.5 V - $40 \dots 105\text{ }^\circ\text{C}$
Theoretical sensitivity	$G_{th}$	V/A		0.2		
Sensitivity error	$\epsilon_G$	%	-1.6	0.5	1.6	$R_L > 500\text{ k}\Omega$
Temperature coefficient of G	$TCG$	ppm/K		$\pm 400$		- $40\text{ }^\circ\text{C} \dots 105\text{ }^\circ\text{C}$
Linearity error	$\epsilon_L$	%		0.5	1	
Number of turns (test winding)	$N_T$			20		$R_L > 500\text{ k}\Omega$ , $di/dt > 5\text{ A}/\mu\text{s}$
Reaction time @ 10 % of $I_{PRN}$	$t_{ra}$	$\mu\text{s}$		5		$R_L > 500\text{ k}\Omega$ , $di/dt > 5\text{ A}/\mu\text{s}$
Step response time to 90 % of $I_{PN}$	$t_r$	$\mu\text{s}$		50		$R_L > 500\text{ k}\Omega$ , $di/dt > 5\text{ A}/\mu\text{s}$
Frequency bandwidth (-3dB)	$BW$	kHz		15		$R_L > 500\text{ k}\Omega$
Noise(1 Hz ~ 10 kHz)	$V_{no}$	mV rms		10		$R_L > 500\text{ k}\Omega$
Accuracy@ $I_{PN}$ @ $T_A = 25\text{ }^\circ\text{C}$	$X_{25c}$	% of $I_{PN}$		$\pm 1.9$		
Accuracy@ $I_{PN}$ @ $T_A = 105\text{ }^\circ\text{C}$	$X_{105c}$	% of $I_{PN}$		$\pm 3.2$		

## 10. SFG- P/N1 Dimensions

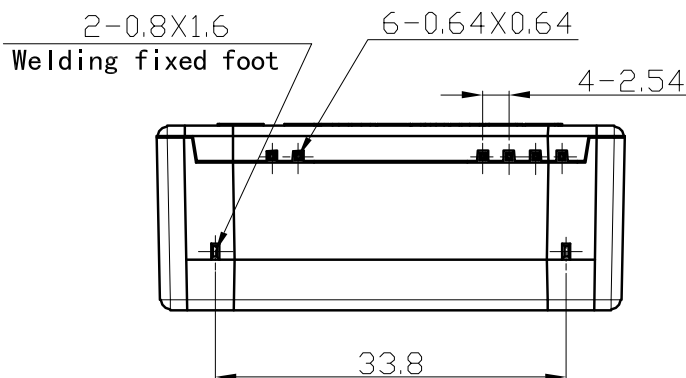
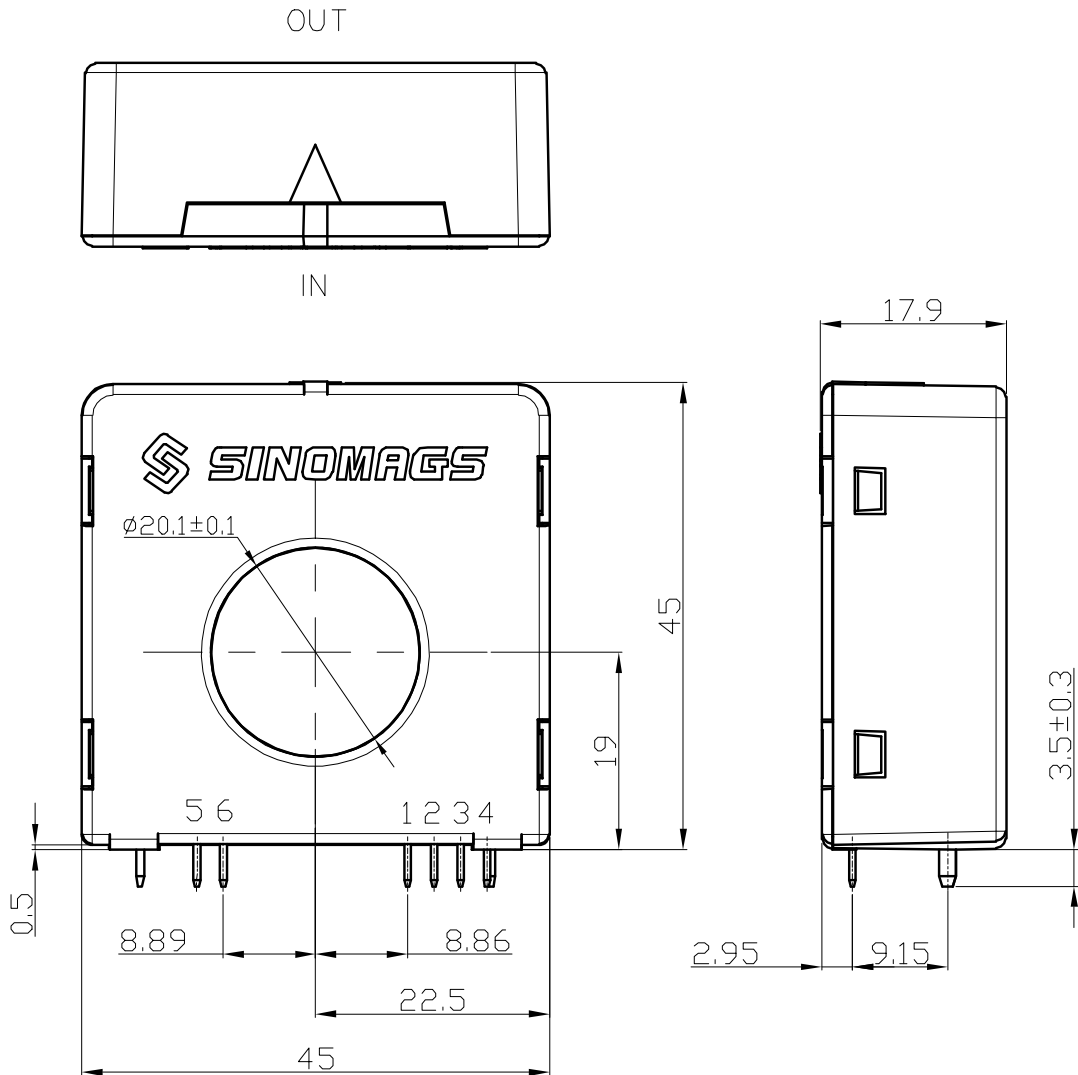

Material : Fit UL94V-0 & RoHS requirements ;

General tolerance : ±0.5

Unit :mm

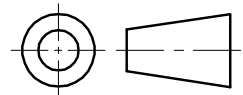

Terminals:

1	2	3
Vcc	Gnd	Ref
4	5	6
Vout	Test Out	Test In

Assembly on PCB:

- 1、Maximum PCB thickness: 2.4mm;
- 2、Wave soldering profile No Pd process only: maximum 260°C, 10S;