

Current Sensor

Product Series: STK-616ZM

Part number: STK-616Z-20MFB5
STK-616Z-30MFB5
STK-616Z-40MFB5
STK-616Z-50MFB5

Version: Ver 1.3

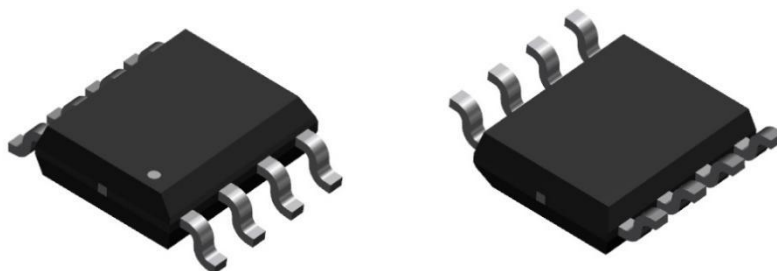

CONTENT

1. Introduction	2
2. Package: SOIC8 compatible	2
3. Selection Guide	3
4. Production Information	3
5. Electrical data STK-616Z-XXMXB5	4
6. Typical Application Circuit	4
7. Characteristic Definitions	5
8. Continues current vs working temperature	5
9. Dimension & Pin Definitions	6
10. Pin definitions	7
11. Frequency bandwidth of STK-616Z-XXMFBX	7
12. Step response time of STK-616Z-XXMFBX	7
13. Frequency bandwidth of STK-616Z-XXMLBX	8
14. Step response time of STK-616Z-XXMLBX	8
15. Dimension & Pin Definitions	9

1. Introduction

STK-616ZM series current sensor is based on TMR (tunnel magneto resistance) technology, and it has an open-loop design. It is suitable for DC, AC pulsed and any kind of irregular current measurement under the isolated conditions.

Typical applications

- AC variable speed drives
- Motor control
- Switching power supply

General parameter

Parameter	Symbol	Unit	Value
Working temperature	T _A	°C	-40 ~ 125
Storage temperature	T _{stg}	°C	-40 ~ 125
Mass	m	g	0.1

Absolute maximum rating

Parameter	Symbol	Unit	Value
Supply voltage	V _{CC}	V	6
ESD rating (HBM)	U _{ESD}	kV	4

Remark: the unrecoverable damage may occur when the product works on the conditions over the absolute maximum ratings. Long-time working on the absolute maximum ratings may cause the degradation on performance and reliability.

Isolation parameter

Parameter	Symbol	Unit	Value	Comment
RMS voltage for AC test 50Hz/1 min	U _d	kV	2.4	All
Clearance distance (Shortest distance through air)	d _{Cl}	mm	4.2	All
Creepage distance (Shortest path along device body)	d _{Cp}	mm	4.2	All

2. Package: SOIC8 compatible

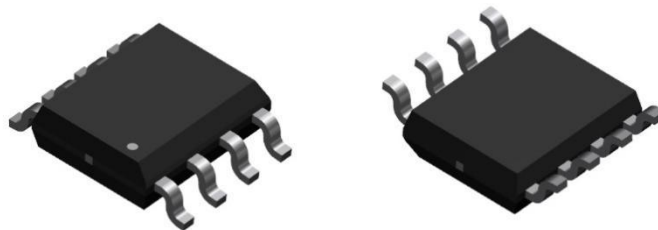

3. Selection Guide

Part Number	Vcc(V)	Current Range (A)	Sensitivity (mV/A)	Offset (V)	Current Directionality	Top(°C)
STK-616Z-20MFB5	5	±20	100	2.5	Bidirectional	-40~125
STK-616Z-30MFB5	5	±30	66.7	2.5	Bidirectional	-40~125
STK-616Z-40MFB5	5	±40	50	2.5	Bidirectional	-40~125
STK-616Z-50MFB5	5	±50	40	2.5	Bidirectional	-40~125

4. Production Information

STK - 616Z - 20MF B - 5

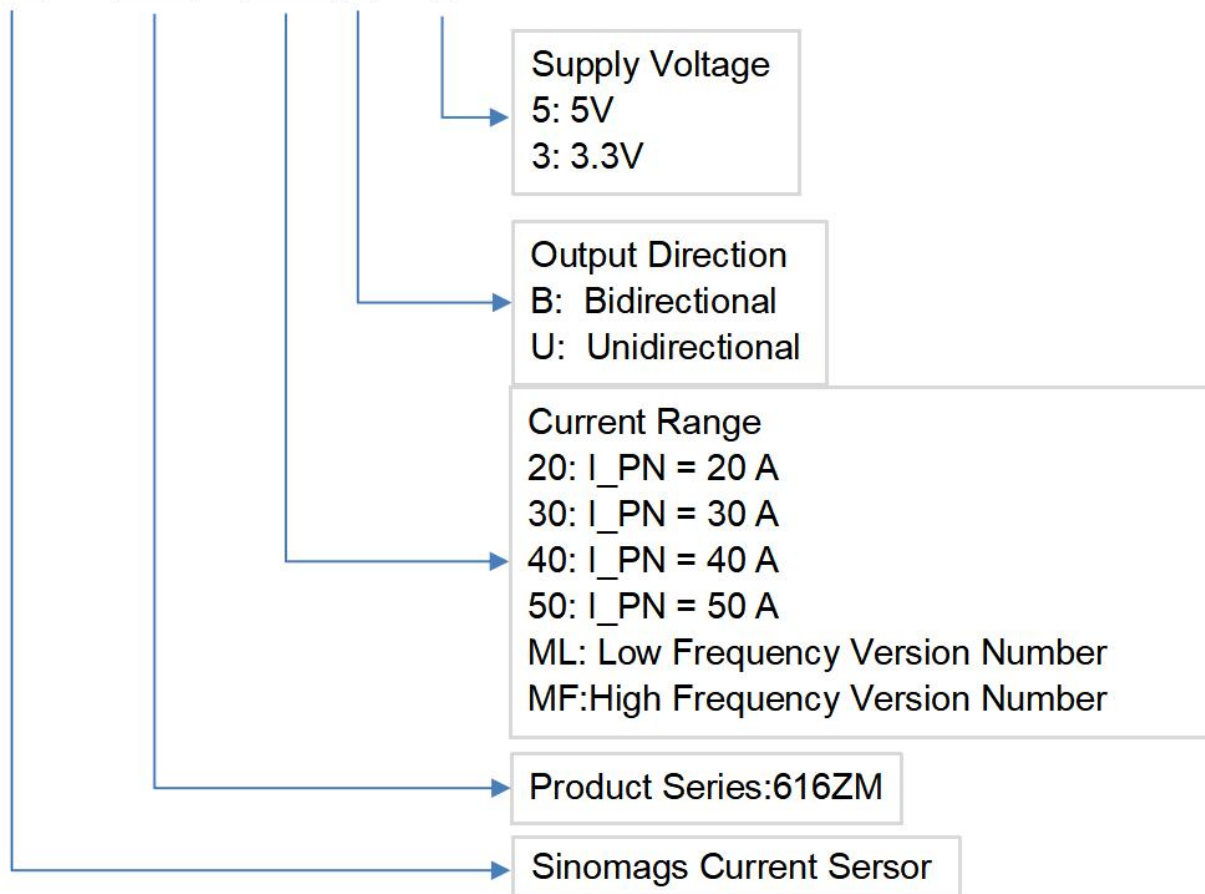

5. Electrical data STK-616Z-XXMFB5

Condition: $T_A = 25^\circ\text{C}$, $V_{CC} = 5\text{V}$

Parameter	Symbol	Unit	Min	Typ	Max	Comment
Supply voltage	V_{CC}	V		5±5%		STK-616Z-XXMFB5
Current consumption	I_{CC}	mA		6		STK-616Z-XXMFB5
Primary conductor resistance	R_{pr}	mΩ		0.9		STK-616Z-XXMFB5
Quiescent voltage Vout @ 0 A	$V_{IOUT(Q)}$	V		2.5±0.05		STK-616Z-XXMFB5
Zero Current Reference Voltage	V_{REF}	V		2.5±0.05		STK-616Z-XXMFB5
Peak output voltage (Vout @ ±I _{pn}) - $V_{IOUT(Q)}$	V_{FS}	V		±2		STK-616Z-XXMFB5
Internal output resistance	R_{out}	Ω		2		STK-616Z-XXMFB5
Rated linearity error	E_{LIN}	% I _{PN}		±1.5		±I _{PN}
Step response time	t_{res}	μs		0.2		@90% of I _{pn} STK-616Z-XXMFB5
Frequency bandwidth (-3dB)	BW	MHz		1.6		@-3dB STK-616Z-XXMFB5
Step response time	t_{res}	μs		1		@90% of I _{pn} STK-616Z-XXMLB5
Frequency bandwidth (-3dB)	BW	MHz		0.4		@-3dB STK-616Z-XXMLB5
Output voltage noise DC ~ 10 kHz DC ~ 100 kHz	V_{noise}	mVpp		20 40		All
Accuracy @ 25°C	E_{TOT}	% of I _{PN}		±1.5		All
Accuracy @ -40°C ~ 105°C	E_{TOT}	% of I _{PN}		±3.5		All

6. Typical Application Circuit

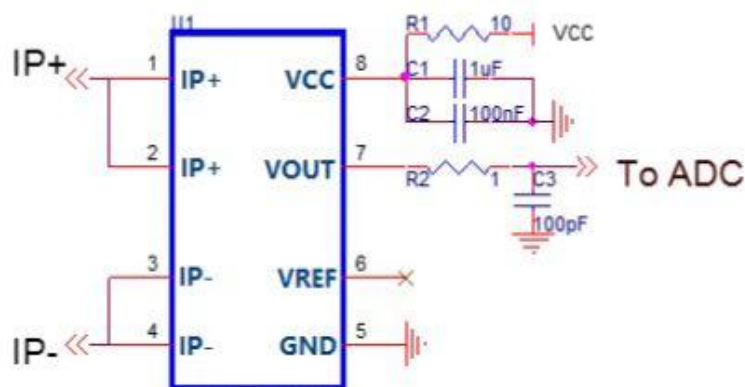

7. Characteristic Definitions

SENSITIVITY (Sens)

The change in sensor output in response to a 1 A change through the primary conductor. The sensitivity is the sensor gain (mv/A) for the full-scale current of the device. The sensitivity is fixed and does not change with the supply voltage.

ZERO CURRENT OUTPUT VOLTAGE (VIOUT(Q))

The output of the sensor when the primary current is zero. When the power supply is 5 V, it nominally remains at 2.5 V for a bidirectional device. When the power supply is 3.3 V, it nominally remains at 1.65 V for a bidirectional device.

8. Continues current vs working temperature

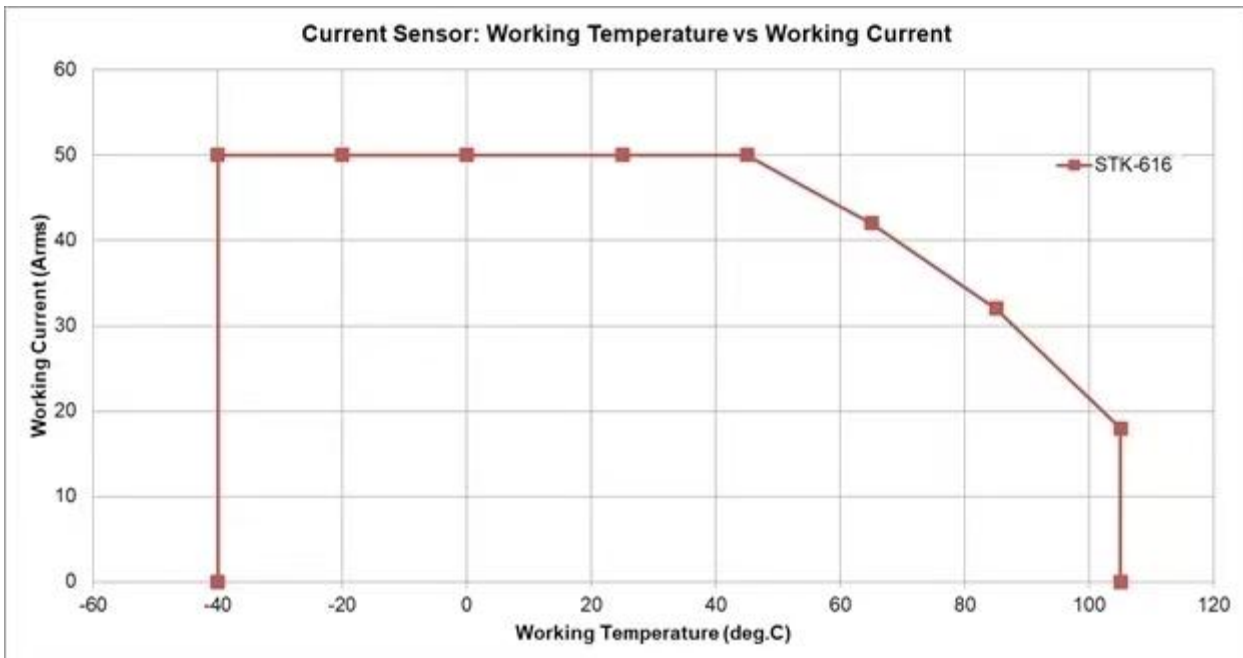

9. Dimension & Pin Definitions

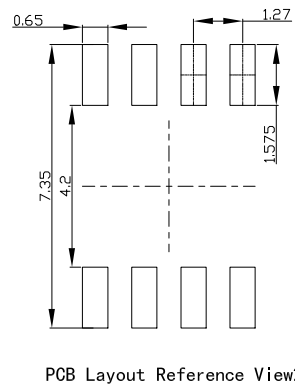
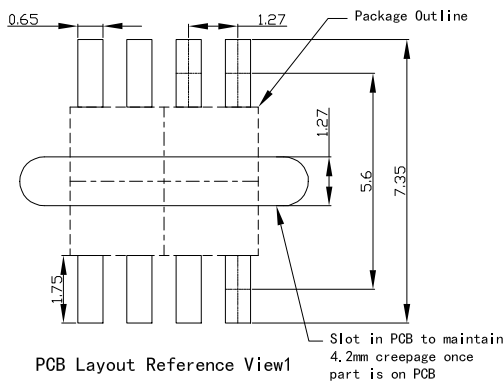
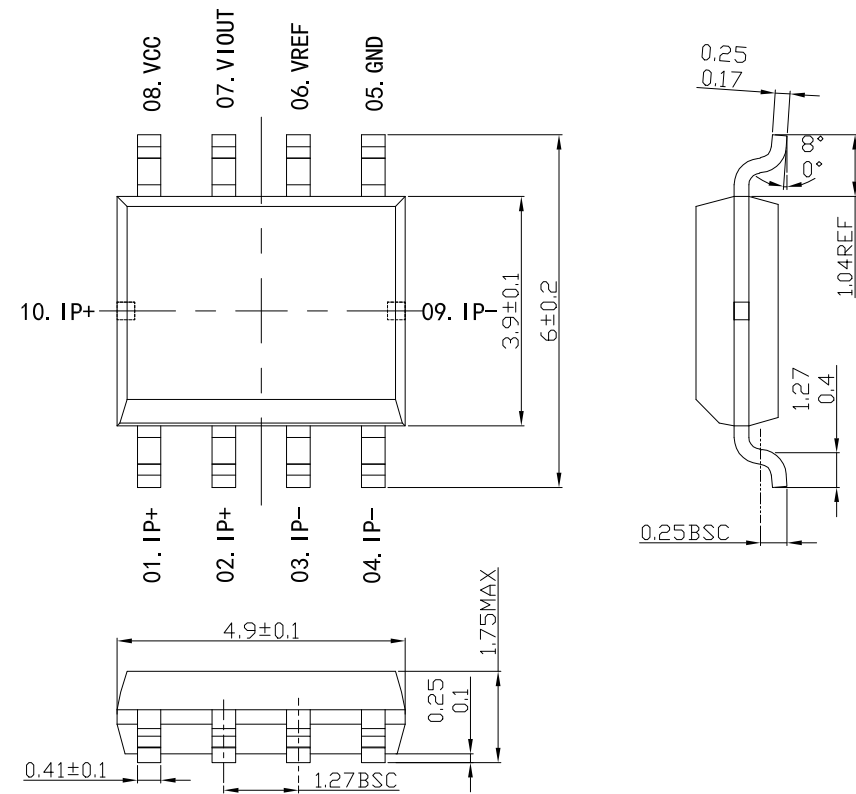

For PCB assemblies that cannot support a slotted design, the above stretched footprint may be used

10. Pin definitions

Pin definition for product with OCD function

PIN	Symbol	Description
1,2	IP+	Primary conductor pin (+)
3,4	IP-	Primary conductor pin (-)
5	GND	Ground pin (GND)
6	VREF	Zero current voltage reference
7	VIOUT	Sensor output pin
8	VCC	Power supply pin

11. Frequency bandwidth of STK-616Z-XXMFBX

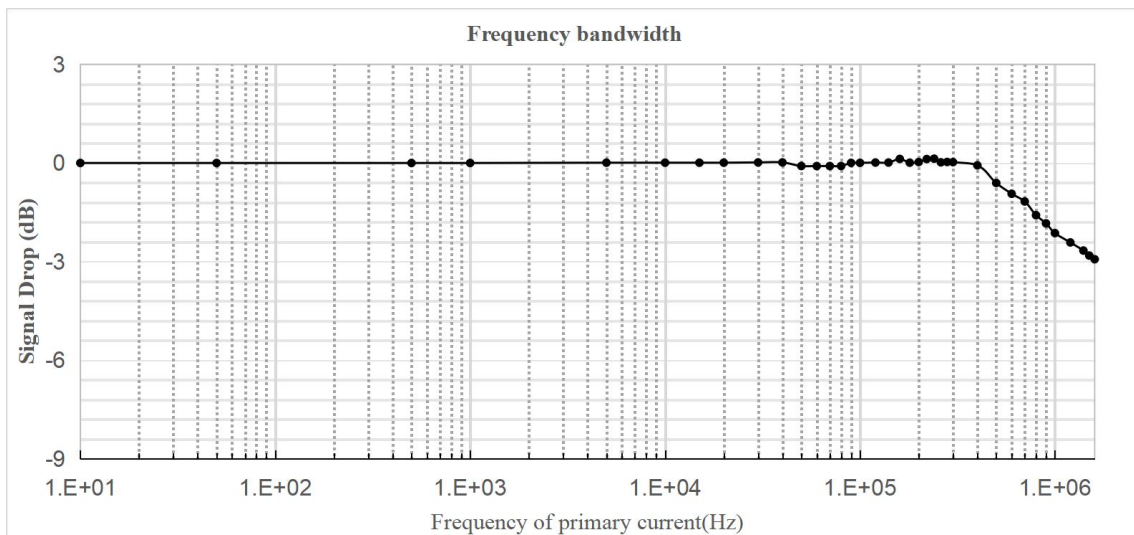

12. Step response time of STK-616Z-XXMFBX

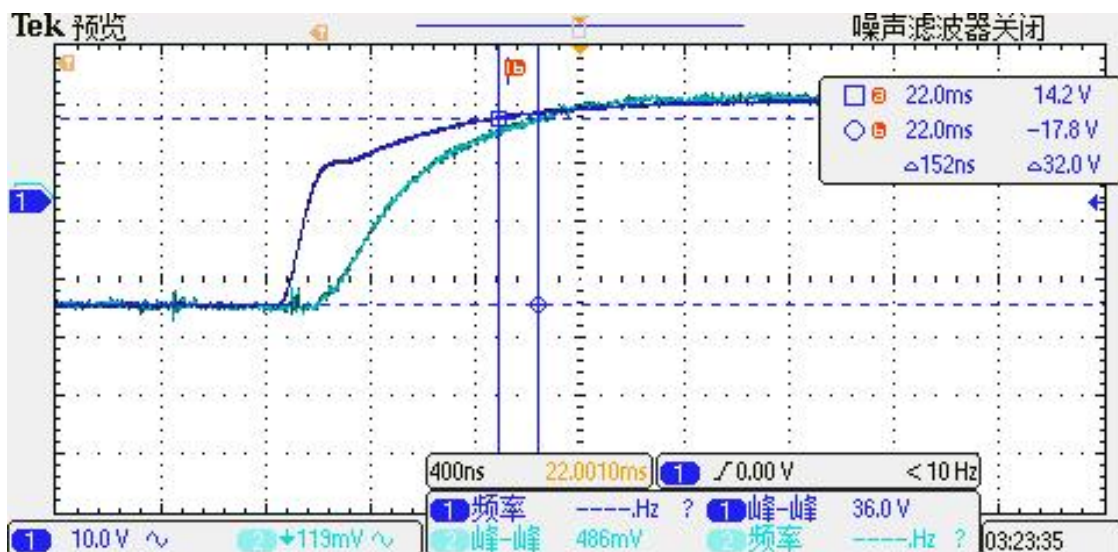

The typical frequency response of STK-616Z current sensor. The response time from 90% of the primary current to 90% of the secondary output is 0.2 μ s.

13. Frequency bandwidth of STK-616Z-XXMLBX

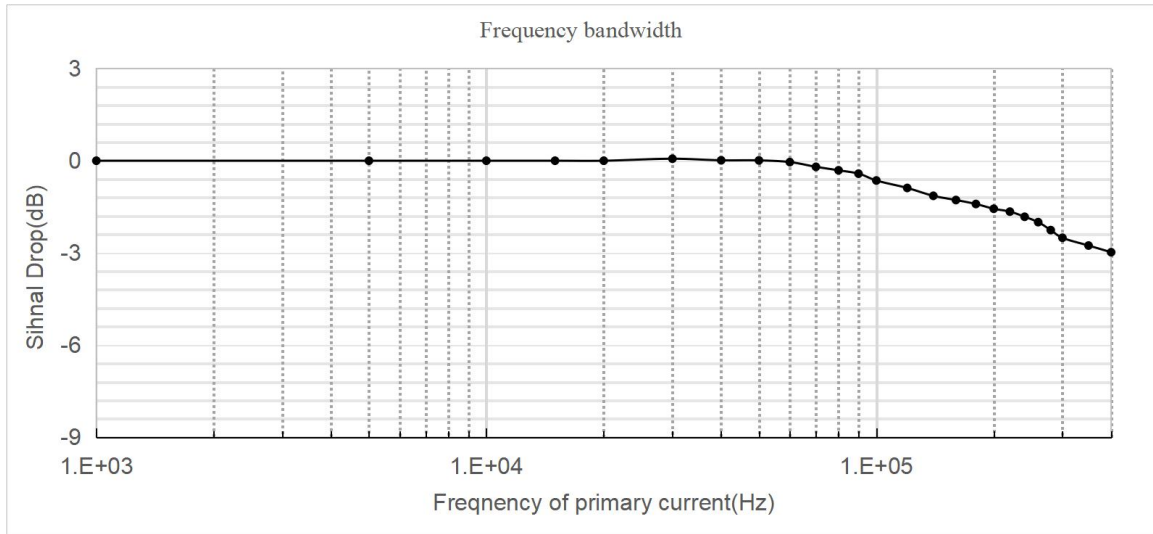

14. Step response time of STK-616Z-XXMLBX

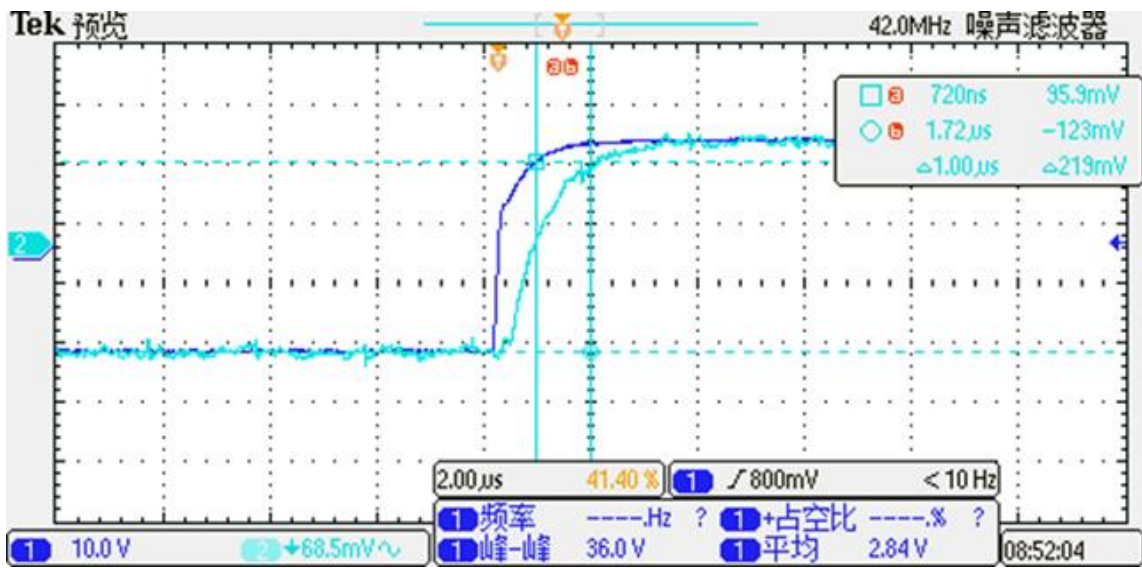

The typical frequency response of STK-616Z current sensor. The response time from 90% of the primary current to 90% of the secondary output is 1 µs.

15. Dimension & Pin Definitions

TAPE AND REEL INFORMATION

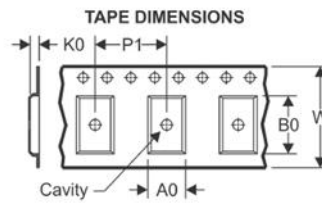
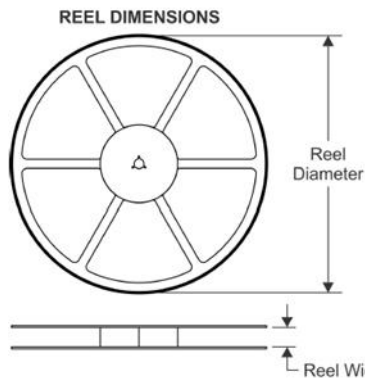

A0	Dimension designed to accommodate the component width
B0	Dimension designed to accommodate the component length
K0	Dimension designed to accommodate the component thickness
W	Overall width of the carrier tape
P1	Pitch between successive cavity centers

QUADRANT ASSIGNMENTS FOR PIN 1 ORIENTATION IN TAPE

